



KOSHIN

KOSHIN LTD.

12 Kami-Hachinotsubo Kotari,
Nagaokakyo City, Kyoto 617-8511 JAPAN
TEL. +81-75-954-6111 FAX. +81-75-954-6119
www.koshinpump.com

KOSHIN CHINA LIMITED
KOSHIN LTD. SINGAPORE OFFICE
KOSHIN AMERICA CORP.

KOSHIN (THAILAND) CO.,LTD.
KOSHIN LITIAN PUMP (NINGBO) CO., LTD.

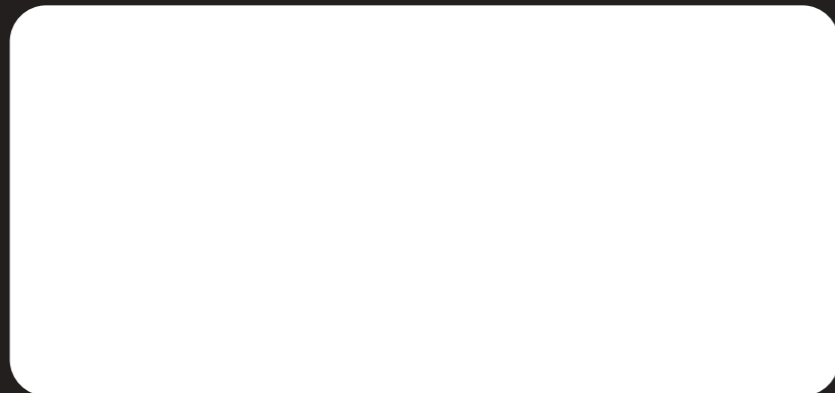

0801-01T

KOSHIN LTD.

Trusted in 130 Countries for High Quality



- HIDELS PUMPS4
- TRASH PUMPS.....10
- SEMI TRASH PUMPS13
- HIGH PRESSURE PUMPS14
- PABOOL PUMPS16
- AGRO MATE (THERMOPLASTIC PUMPS) ...18
- PONDY (SUBMERSIBLE PUMPS).....19
- PONSTAR (SUBMERSIBLE PUMPS).....20
- GENERATORS.....24
- MISTER AUTO (GARDEN SPRAYERS)26
- GARDEN MASTER (DRY CELL BATTERY SPRAYERS)27
- KIRI MEGAMI (POWER SPRAYERS)28
- GROUND MASTER (BACKPACK MANUAL SPRAYERS) ...29
- KIRI SEN-NIN (BACKPACK RECHARGEABLE BATTERY SPRAYER) ..29
- GEAR PUMPS (GL SERIES)30
- CHANGE MASTER, FS PUMPS31
- GEAR PUMPS (GB/GC SERIES)32
- PACO-PET, MAMA-AUTO33
- DRUM PUMPS.....34
- FILL PUMPS36
- MINI CARL (BATTERY WINCHES)38
- ECARL (BATTERY WINCHES).....40
- MAG-ROLLER (BATTERY WINCHES).....45
- MARINE PET, PONDY (SUBMERSIBLE PUMPS)46
- NEW BILGE KING47
- REVOLVEX PUMPS.....48
- FS PUMPS (FOR SEAWATER)51

Headquarters (Kyoto, Japan)



Koshin Litian Pump (Ningbo) Co.,Ltd.



Koshin (Thailand) Co.,Ltd.



We Guarantee All Specifications

▼ Explanation of pictogram

GARDENING	IRRIGATION	SPRINKLER	FIRE FIGHTING	WASHING	HIGH LIFT	FISH TANK	ON BOAT	200 L DRUM CAN	SILICON CARBIDE MECHANICAL SEAL	QUIET
CIRCULATION	CONSTRUCTION	SHALLOW WELL	FISH FARM	SEA WATER	CHEMICALS	HOME SWIMMING POOL	OIL (VISCOSITY)	RECHARGEABLE BATTERY	DRY CELL BATTERY	ENVIRONMENT



PORTABLE & POWERFUL

Light 2 Stroke Engine Pumps



Super Light



SE-25L

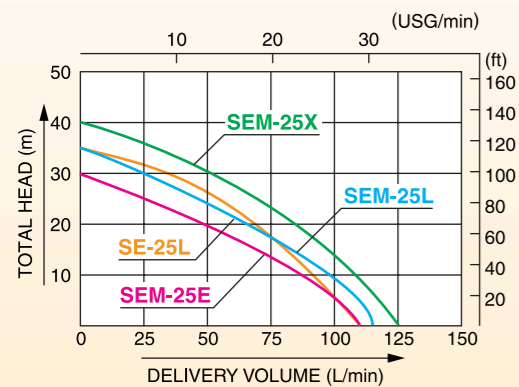

SEM-25L



SEM-25X

Up to 50% Fuel Saving & Noise Reduction* Double Life Span

* Fuel consumption and engine noise are half of 2 stroke engine.



Performance Curve

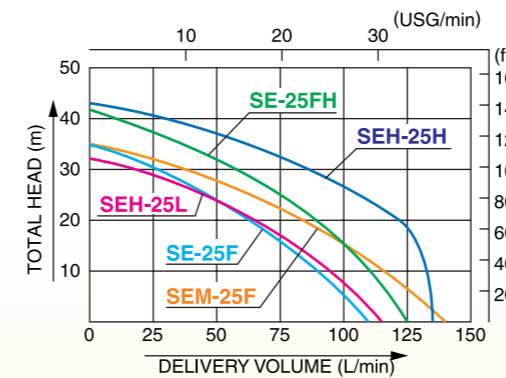

SE-25FH

SEH-25H

SEH-25L

Available 25 mm Hose Set

N-Type Hose Set

- Washing of agriculture & construction machinery



- 1 Delivery hose (8 m)
- 1 Nozzle (Jet)

R-Type Hose Set

- Washing of agriculture machinery
- Water sprinkling to the field



- 1 Delivery hose (8 m)
- 1 Nozzle (Jet & Mist)

New Spray Nozzle



SJ-20

- Large volume of spraying water
- 1 Coupling set (20 mm)
- 1 Hose nipple (20 mm x 15 mm)



Specifications

Model	SE-25L	SEM-25X	SEM-25L	SEM-25E
Connection Dia	25 mm (1")			
Connection Thread	Outer Pipe Thread			
Total Head	35 m (115 ft)	40 m (131 ft)	35 m (115 ft)	30 m (98 ft)
Delivery Volume	110 L/min (29 USG/min)	125 L/min (33 USG/min)	115 L/min (30 USG/min)	110 L/min (29 USG/min)
Max. Suction Head	8 m (26 ft)			
Type	Forced Air Cooling 2 Stroke Gasoline Engine			
Model	Robin EC025GR	Mitsubishi TL33	Mitsubishi TU26	Mitsubishi TLE20
Exhaust Volume	24.5 cc	32.6 cc	25.6 cc	19.8 cc
Rated Output	0.55 kW (0.75 PS) / 6000 rpm	—	—	—
Max. Output	0.88 kW (1.2 PS) / 7000 rpm	1.27 kW (1.7 PS) / 7000 rpm	1.03 kW (1.4 PS) / 7500 rpm	0.82 kW (1.1 PS) / 7500 rpm
Fuel	2 Stroke Mixed Gas and Oil			
Fuel Tank Capacity	0.6 L	0.9 L	0.6 L	0.4 L
Continuous Operating Time	Approx. 50 min	Approx. 60 min	Approx. 60 min	
Starting Method	Recoil Starter			
Standard Accessories	1 Strainer, 2 Hose Couplings, 3 Hose Bands, 1 Engine Tool Set			
Gross Weight	6.0 kg	9.0 kg	6.5 kg	
Dimensions LxWxH (mm)	310 x 255 x 347	365 x 273 x 410	345 x 260 x 345	320 x 280 x 353
Packing Unit	1			

Specifications

Model	SE-25F	SE-25FH	SEH-25L	SEH-25H	SEM-25F
Connection Dia	25 mm (1")				
Connection Thread	Outer Pipe Thread				
Total Head	35 m (115 ft)	42 m (138 ft)	32 m (105 ft)	43 m (141 ft)	35 m (115 ft)
Delivery Volume	110 L/min (29 USG/min)	125 L/min (33 USG/min)	115 L/min (30 USG/min)	135 L/min (36 USG/min)	140 L/min (37 USG/min)
Max. Suction Head	8 m (26 ft)				
Type	Forced Air Cooling 4 Stroke Gasoline Engine				
Model	Robin EH025	Robin EH035	Honda GX25	Honda GXH50	Mitsubishi GM82
Exhaust Volume	24.5 cc	33.5 cc	25 cc	49.4 cc	80 cc
Rated Output	0.55 kW (0.75 PS) / 7000 rpm	0.81 kW (1.1 PS) / 7000 rpm	—	—	1.3 kW (1.8 PS) / 3600 rpm
Max. Output	0.81 kW (1.1 PS) / 7000 rpm	1.18 kW (1.6 PS) / 7000 rpm	0.72 kW (1.0 PS) / 7000 rpm	1.6 kW (2.2 PS) / 7000 rpm	1.8 kW (2.4 PS)
Fuel	Automotive Unleaded Gasoline				
Fuel Tank Capacity	0.5 L	0.65 L	0.58 L	0.77 L	1.6 L
Continuous Operating Time	Approx. 60 min	Approx. 50 min	Approx. 1 hr	Approx. 50 min	Approx. 2 hrs 50 min
Starting Method	Recoil Starter				
Standard Accessories	1 Strainer, 2 Hose Couplings, 3 Hose Bands, 1 Engine Tool Set				
Gross Weight	6.6 kg	9.5 kg	7 kg	12.5 kg	17 kg
Dimensions LxWxH (mm)	398 x 300 x 355	398 x 300 x 355	398 x 300 x 355	398 x 300 x 355	465 x 360 x 390
Packing Unit	1				

Strong & Durable Robin Engine

- Highly effective mechanical seal made with special carbon ceramics provides extra durability.
- Entire unit is protected by sturdy rollover pipe frame.
- Strong and lightweight die-cast aluminum pump.



Performance Curve

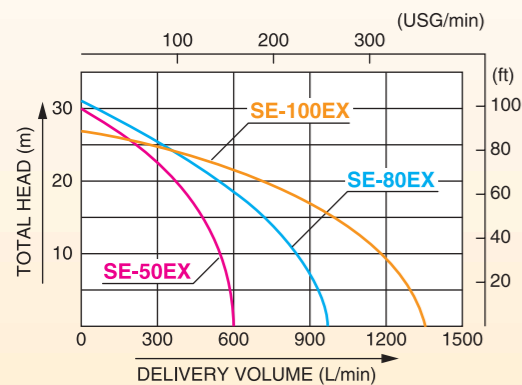
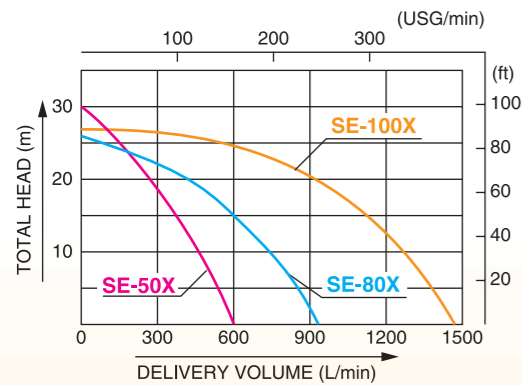

Specifications

Model	SE-50X	SE-80X	SE-100X	SE-50EX	SE-80EX	SE-100EX
Connection Dia	50 mm (2")	80 mm (3")	100 mm (4")	50 mm (2")	80 mm (3")	100 mm (4")
Connection Thread	Outer Pipe Thread					
Total Head	30 m (98 ft)	26 m (85 ft)	28 m (92 ft)	30 m (98 ft)	31 m (102 ft)	27 m (89 ft)
Delivery Volume	600 L/min (158 USG/min)	930 L/min (246 USG/min)	1450 L/min (383 USG/min)	600 L/min (158 USG/min)	970 L/min (256 USG/min)	1350 L/min (356 USG/min)
Max. Suction Head	8 m (26 ft)					
Type	Forced Air Cooling 4 Stroke Gasoline Engine					
Model	Robin EY15-3D	Robin EY20-3D	Robin EY28-D	Robin EX13	Robin EX17	Robin EX27
Exhaust Volume	143 cc	183 cc	273 cc	126 cc	169 cc	265 cc
Rated Output	2.0 kW (2.7 PS) / 3600 rpm	2.6 kW (3.5 PS) / 3600 rpm	4.0 kW (5.5 PS) / 3600 rpm	2.2 kW (3.0 PS) / 3600 rpm	2.9 kW (4.0 PS) / 3600 rpm	5.1 kW (7.0 PS) / 3600 rpm
Max. Output	2.6 kW (3.5 PS) / 4000 rpm	3.7 kW (5.0 PS) / 4000 rpm	5.5 kW (7.5 PS) / 4000 rpm	3.2 kW (4.3 PS) / 4000 rpm	4.2 kW (5.7 PS) / 4000 rpm	6.6 kW (9.0 PS) / 4000 rpm
Fuel	Automotive Unleaded Gasoline					
Fuel Tank Capacity	2.8 L	3.8 L	5.5 L	2.7 L	3.6 L	6.1 L
Continuous Operating Time	Approx. 2 hrs 40 min	Approx. 3 hrs		Approx. 2 hrs 40 min	Approx. 2 hrs 30 min	
Starting Method	Recoil Starter					
Standard Accessories	1 Strainer, 2 Hose Couplings, 3 Hose Bands, 1 Engine Tool Set					
Gross Weight	23 kg	34 kg	55 kg	24 kg	30 kg	55 kg
Dimensions LxWxH (mm)	489 x 340 x 435	535 x 380 x 487	650 x 453 x 660	500 x 395 x 440	540 x 400 x 480	487 x 680 x 684
Packing Unit	1					

Kerosene Engine Pumps



Performance Curve

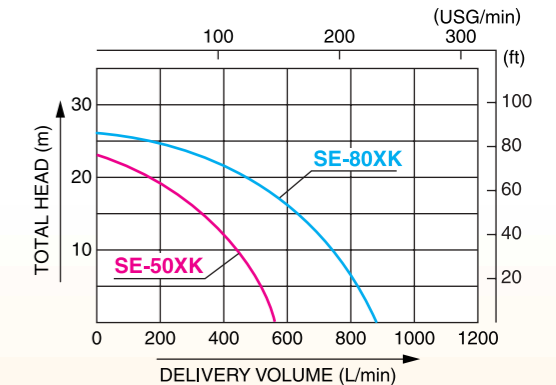

Diesel Engine Pumps

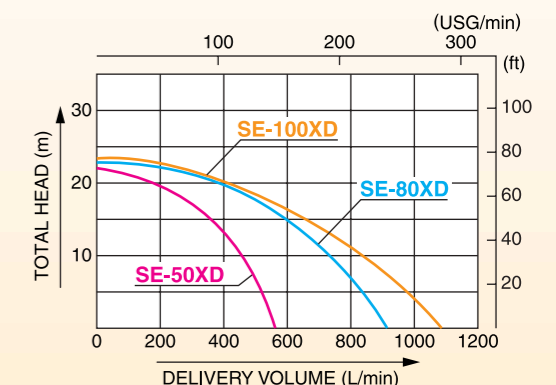

Specifications

Model	SE-50XK	SE-80XK	SE-50XD	SE-80XD	SE-100XD
Connection Dia	50 mm (2")	80 mm (3")	50 mm (2")	80 mm (3")	100 mm (4")
Connection Thread	Outer Pipe Thread				
Total Head	23 m (75 ft)	26 m (85 ft)	23 m (75 ft)		24 m (79 ft)
Delivery Volume	560 L/min (148 USG/min)	880 L/min (232 USG/min)	560 L/min (148 USG/min)	900 L/min (238 USG/min)	1100 L/min (290 USG/min)
Max. Suction Head	8 m (26 ft)				
Type	Forced Air Cooling 4 Stroke Kerosene Engine		Forced Air Cooling 4 Stroke Diesel Engine		
Model	Robin EY15-3DK	Robin EY20-3DK	Robin DY23-2D		Robin DY27-2D
Exhaust Volume	143 cc	183 cc	230 cc		265 cc
Rated Output	1.6 kW (2.2 PS) / 3600 rpm	2.3 kW (3.1 PS) / 3600 rpm	3.1 kW (4.2 PS) / 3600 rpm		3.7 kW (5.0 PS) / 3600 rpm
Max. Output	2.4 kW (3.3 PS) / 4000 rpm	3.2 kW (4.3 PS) / 4000 rpm	3.7 kW (5.0 PS) / 3600 rpm		4.0 kW (5.5 PS) / 3600 rpm
Fuel	Kerosene (Gasoline for starting)		Diesel		
Fuel Tank Capacity	Kerosene: 2.6 L Gasoline: 0.13 L	Kerosene: 3.4 L Gasoline: 0.17 L	3.2 L		
Continuous Operating Time	Approx. 2 hrs 30 min		Approx. 3 hrs 30 min	Approx. 3 hrs	Approx. 2 hrs 30 min
Starting Method	Recoil Starter				
Standard Accessories	1 Strainer, 2 Hose Couplings, 3 Hose Bands, 1 Engine Tool Set				
Gross Weight	25 kg	34 kg	47 kg	50 kg	64 kg
Dimensions LxWxH (mm)	489 x 362 x 435	535 x 380 x 487	583 x 423 x 515	583 x 423 x 515	674 x 455 x 713
Packing Unit	1				

Complete Range of Water Pumps Powered by **Honda** Engine

- Highly effective mechanical seal made with special carbon ceramics provides extra durability.
- Entire unit is protected by sturdy rollover pipe frame.
- Strong and lightweight die-cast aluminum pump.



SEH-50X



SEH-80X

■ Performance Curve

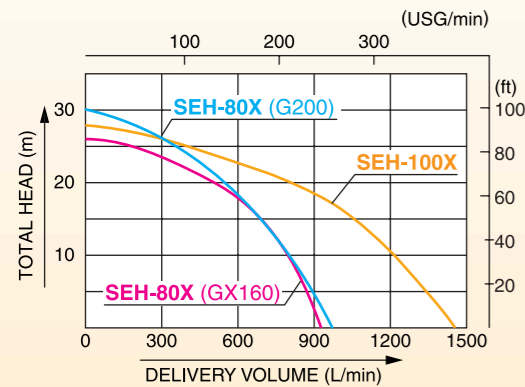
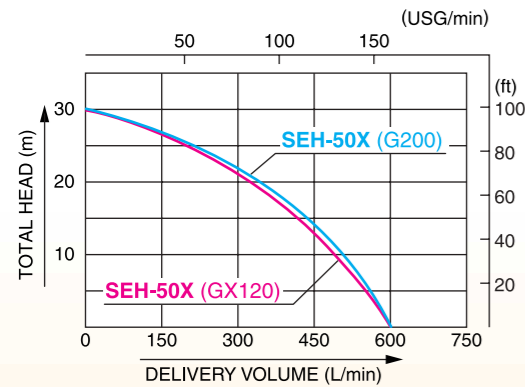

■ Specifications

	SEH-50X		SEH-80X		SEH-100X	
PUMP	Model					
	Connection Dia	50 mm (2")		80 mm (3")	100 mm (4")	
	Connection Thread	Outer Pipe Thread				
	Total Head	30 m (98 ft)		26 m (85 ft)	28 m (92 ft)	
	Delivery Volume	600 L/min (158 USG/min)		930 L/min (246 USG/min)	1450 L/min (383 USG/min)	
Max. Suction Head	8 m (26 ft)					
ENGINE	Type	Forced Air Cooling 4 Stroke Gasoline Engine				
	Model	Honda GX120	Honda G200	Honda GX160	Honda G200	Honda GX240
	Exhaust Volume	118 cc	197 cc	163 cc	197 cc	242 cc
	Rated Output	2.1 kW (2.9 PS) / 3600 rpm	2.8 kW (3.8 PS) / 3600 rpm	2.9 kW (3.9 PS) / 3600 rpm	2.8 kW (3.8 PS) / 3600 rpm	4.4 kW (6.0 PS) / 3600 rpm
	Max. Output	2.6 kW (3.5 PS) / 3600 rpm	3.7 kW (5.0 PS) / 3600 rpm	3.6 kW (4.9 PS) / 3600 rpm	3.7 kW (5.0 PS) / 3600 rpm	5.3 kW (7.2 PS) / 3600 rpm
	Fuel	Automotive Unleaded Gasoline				
	Fuel Tank Capacity	2 L	4.3 L	3.1 L	4.3 L	5.3 L
	Continuous Operating Time	Approx. 2 hrs	Approx. 3 hrs	Approx. 2 hrs 10 min	Approx. 3 hrs	Approx. 2 hrs 30 min
	Starting Method	Recoil Starter				
	Standard Accessories	1 Strainer, 2 Hose Couplings, 3 Hose Bands, 1 Engine Tool Set				
Gross Weight	24 kg	29 kg	34 kg	32 kg	59 kg	
Dimensions LxWxH (mm)	493 x 377 x 415	527 x 429 x 535	530 x 399 x 473	527 x 429 x 535	680 x 487 x 684	
Packing Unit	1					

Powered by Durable **Mitsubishi** Engine

- Highly effective mechanical seal made with special carbon ceramics provides extra durability.
- Entire unit is protected by sturdy rollover pipe frame.
- Strong and lightweight die-cast aluminum pump.



SEM-40F



SEM-80X



SEM-100X

■ Performance Curve

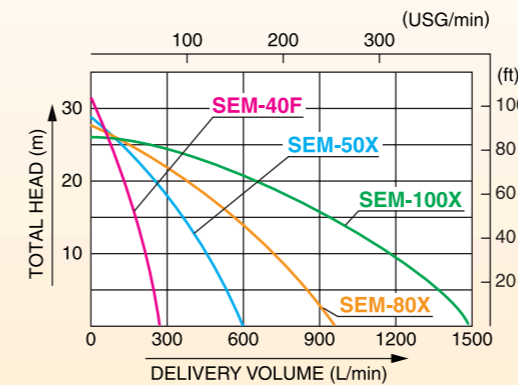

■ Specifications

	SEM-40F	SEM-50X	SEM-80X	SEM-100X	
PUMP	Model				
	Connection Dia	40 mm (1½")	50 mm (2")	80 mm (3")	100 mm (4")
	Connection Thread	Outer Pipe Thread			
	Total Head	32 m (105 ft)	30 m (98 ft)	29 m (95 ft)	28 m (92 ft)
	Delivery Volume	270 L/min (71 USG/min)	600 L/min (158 USG/min)	970 L/min (256 USG/min)	1380 L/min (365 USG/min)
Max. Suction Head	8 m (26 ft)				
ENGINE	Type	Forced Air Cooling 4 Stroke Gasoline Engine			
	Model	Mitsubishi GM82	Mitsubishi GM132	Mitsubishi GM182	Mitsubishi GM231
	Exhaust Volume	80 cc	126 cc	181 cc	215 cc
	Rated Output	1.3 kW (1.8 PS) / 3600 rpm	2.1 kW (2.8 PS) / 3600 rpm	3.3 kW (4.5 PS) / 3600 rpm	3.7 kW (5.0 PS) / 3600 rpm
	Max. Output	1.8 kW (2.4 PS)	2.9 kW (4.0 PS)	4.4 kW (6.0 PS)	5.1 kW (7.0 PS)
	Fuel	Automotive Unleaded Gasoline			
	Fuel Tank Capacity	1.6 L	2.5 L	3.8 L	4.5 L
	Continuous Operating Time	Approx. 2 hrs 50 min		Approx. 3 hrs	
	Starting Method	Recoil Starter			
	Standard Accessories	1 Strainer, 2 Hose Couplings, 3 Hose Bands, 1 Engine Tools Set			
Gross Weight	19 kg	25 kg	33 kg	52 kg	
Dimensions LxWxH (mm)	493 x 377 x 406	506 x 402 x 444	539 x 429 x 512	650 x 462 x 640	
Packing Unit	1				



HEAVY DUTY

Koshin Trash Pumps

•Excellent Seal Durability

Conventional mechanical seal using carbon ceramic is replaced by silicon carbide (SiC) seal. SiC seal is developed by Koshin and we are the first manufacturer to use such durable material in Japan.

•Thoughtful Design

Special plug designed on impeller allows easy removal. Simply insert any rod and twist to separate impeller from its casing. No special tool required.

•Light Weight & Compact Design

Conventional trash pumps are very bulky and heavy, some more than 100 kg in weight. KTR-100X, the largest of all, weights only 81 kg. The compact design takes up smaller space and is portable.

•High Self-priming Performance

Special structure is designed to ensure high capacity self-priming performance. Koshin trash pumps give excellent performance and durability.

Easy & Quick Maintenance

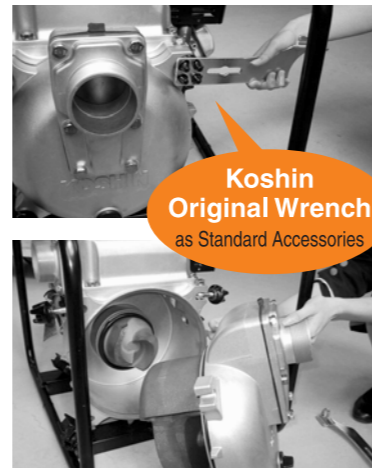

Special Material for Koshin Trash Pumps

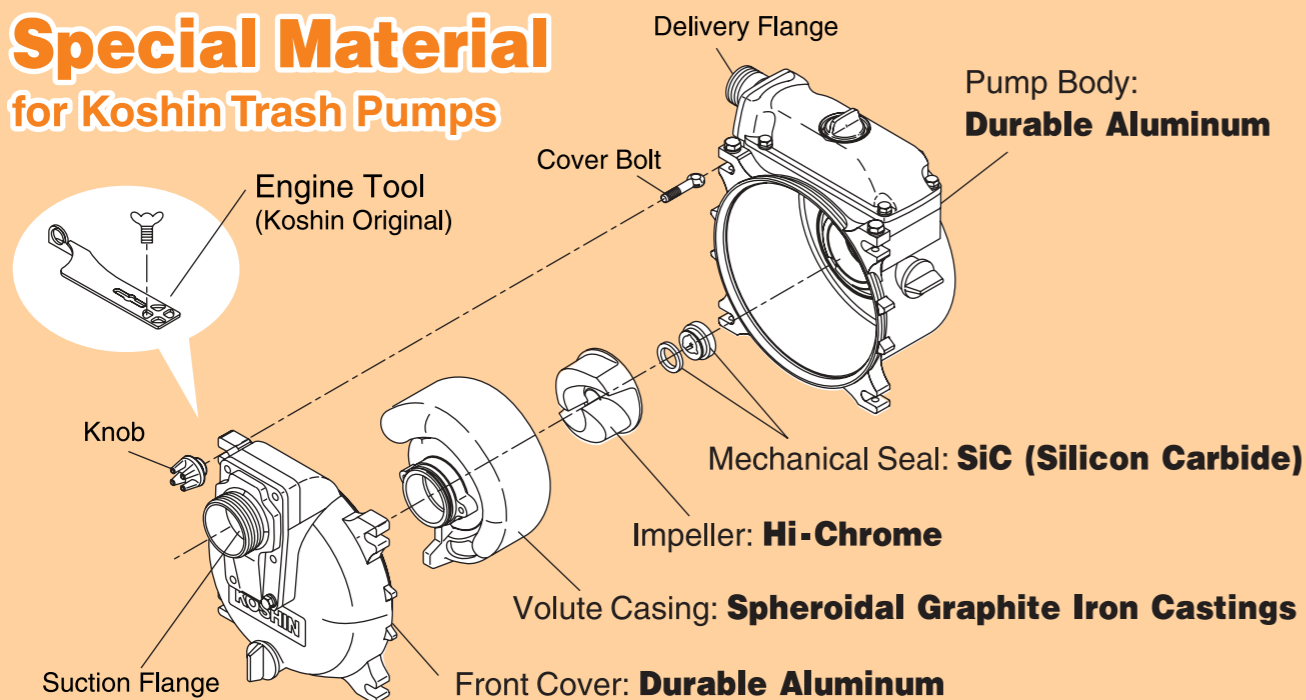

Heavy Duty Trash Pumps Powered by Robin Engine



Solid Sizes

Max. 20 mm

Max. 27 mm

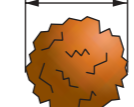

50X Type

80X & 100X Type



■ Performance Curve

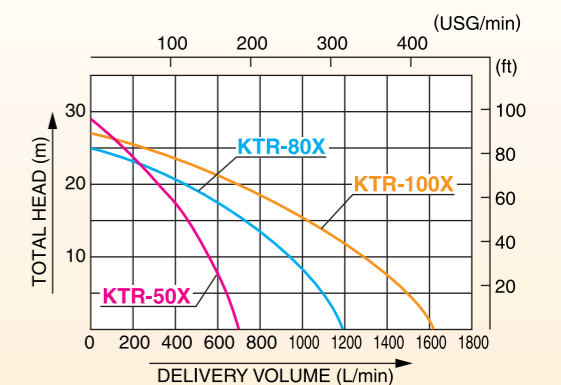

■ Specifications

	Model	KTR-50X	KTR-80X	KTR-100X
PUMP	Connection Dia	50 mm (2")	80 mm (3")	100 mm (4")
	Connection Thread	Outer Pipe Thread		
	Total Head	29 m (95 ft)	25 m (82 ft)	27 m (88 ft)
	Delivery Volume	700 L/min (185 USG/min)	1190 L/min (314 USG/min)	1530 L/min (404 USG/min)
	Max. Suction Head	8 m (26 ft)		
ENGINE	Material for Mechanical Seal	SiC (Silicon Carbide) × SiC		
	Material for Impeller	Hi-Chrome		
	Material for Volute	Spheroidal Graphite Iron Castings		
	Type	Forced Air Cooling 4 Stroke Gasoline Engine		
	Model	Robin EX17	Robin EX27	Robin EH41
	Exhaust Volume	169 cc	265 cc	404 cc
	Rated Output	2.9 kW (4.0 PS) / 3600 rpm	5.1 kW (7.0 PS) / 3600 rpm	6.3 kW (8.5 PS) / 3600 rpm
	Max. Output	4.2 kW (5.7 PS) / 4000 rpm	6.6 kW (9.0 PS) / 4000 rpm	7.0 kW (9.5 PS) / 3600 rpm
	Fuel	Automotive Unleaded Gasoline		
	Fuel Tank Capacity	3.6 L	6.1 L	7.0 L
Continuous Operating Time	Approx. 2 hrs 30 min	Approx. 2 hrs 10 min	3 hrs	
Starting Method	Recoil starter			
Standard Accessories	1 Strainer, 2 Hose Couplings, 3 Hose Bands, 1 Engine Tool Set			
Gross Weight	51 kg	63 kg	81 kg	
Dimensions LxWxH (mm)	656 × 499 × 524	721 × 516 × 585		
Packing Unit	1			

Heavy Duty Trash Pumps Powered by **Honda & Mitsubishi** Engine



KTH-50X



KTM-80X

Performance Curve

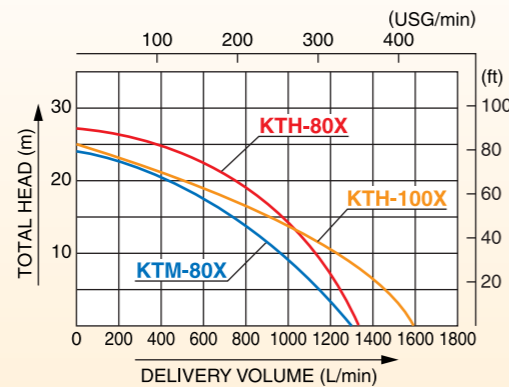
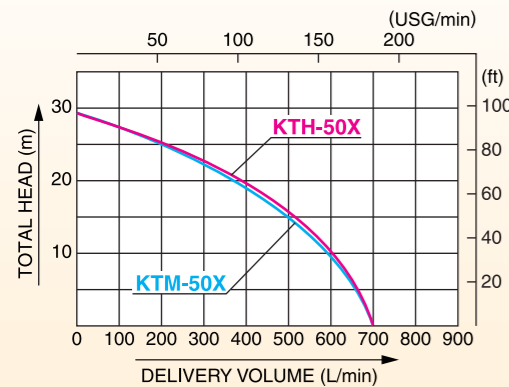

Specifications

Model	KTH-50X	KTH-80X	KTH-100X	KTM-50X	KTM-80X
Connection Dia	50 mm (2")	80 mm (3")	100 mm (4")	50 mm (2")	80 mm (3")
Connection Thread	Outer Pipe Thread				
Total Head	30 m (98 ft)	27 m (89 ft)	25 m (82 ft)	29 m (95 ft)	24 m (78 ft)
Delivery Volume	700 L/min (185 USG/min)	1340 L/min (354 USG/min)	1600 L/min (422 USG/min)	700 L/min (185 USG/min)	1300 L/min (343 USG/min)
Max. Suction Head	8 m (26 ft)				
Material for Mechanical Seal	SiC (Silicon Carbide) x SiC				
Material for Impeller	Hi-Chrome				
Material for Volute	Spheroidal Graphite Iron Castings				
Type	Forced Air Cooling 4 Stroke Gasoline Engine				
Model	Honda GX160	Honda GX240	Honda GX340	Mitsubishi GM182	Mitsubishi GM291
Exhaust Volume	163 cc	242 cc	337 cc	181 cc	296 cc
Rated Output	2.9 kW (3.9 PS) / 3600 rpm	4.4 kW (6.0 PS) / 3600 rpm	5.8 kW (7.9 PS) / 3600 rpm	4.5 PS (3.3 kW) / 3600 rpm	6.0 PS (4.4 kW) / 3600 rpm
Max. Output	3.6 kW (4.9 PS) / 3600 rpm	5.3 kW (7.2 PS) / 3600 rpm	7.1 kW (9.7 PS) / 3600 rpm	6.0 PS (4.5 kW) / 4000 rpm	8.0 PS (5.9 kW) / 4000 rpm
Fuel	Automotive Unleaded Gasoline				
Fuel Tank Capacity	3.1 L	5.3 L	6.1 L	3.8 L	6.0 L
Continuous Operating Time	Approx. 2 hrs 10 min	Approx. 2 hrs 30 min	Approx. 2 hrs	Approx. 3 hrs	
Starting Method	Recoil Starter				
Standard Accessories	1 Strainer, 2 Hose Couplings, 3 Hose Bands, 1 Engine Tool Set				
Gross Weight	51 kg	63 kg	85 kg	55 kg	68 kg
Dimensions LxWxH(mm)	656 x 498 x 524	721 x 516 x 586	790 x 580 x 675	661 x 503 x 524	711 x 526 x 581
Packing Unit	1				

Economical Trash Pumps For Sandy & Muddy Water Applications

- **Silicon Carbide Mechanical Seal (SiC).**
4 to 5 times more durable than standard carbon ceramic mechanical seal.
- Spheroidal graphite iron casting for impeller and casing.
10 times more corrosion resistant than standard FC or cast iron.
- Impeller can be removed easily without special tool.
- Long bolt assembly for easy maintenance.



STR-50EX



STH-80X

Performance Curve

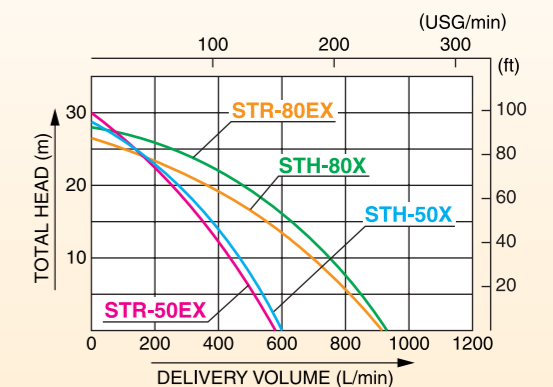

Specifications

Model	STR-50EX	STH-50X	STR-80EX	STH-80X
Connection Dia	50 mm (2")			
Connection Thread	Outer Pipe Thread			
Total Head	30 m (98 ft)	29 m (95 ft)	28 m (92 ft)	26 m (85 ft)
Delivery Volume	580 L/min (153 USG/min)	600 L/min (158 USG/min)	930 L/min (246 USG/min)	900 L/min (237 USG/min)
Max. Suction Head	8 m (26 ft)			
Type	Forced Air Cooling 4 Stroke Gasoline Engine			
Model	Robin EX13	Honda GX120	Robin EX17	Honda GX160
Exhaust Volume	126 cc	118 cc	169 cc	163 cc
Rated Output	2.2 kW (3.0 PS) / 3600 rpm	2.1 kW (2.9 PS) / 3600 rpm	2.9 kW (3.9 PS) / 3600 rpm	2.9 kW (3.9 PS) / 3600 rpm
Max. Output	3.2 kW (4.3 PS) / 4000 rpm	2.6 kW (3.5 PS) / 3600 rpm	4.2 kW (5.7 PS) / 4000 rpm	3.6 kW (4.9 PS) / 3600 rpm
Fuel	Automotive Unleaded Gasoline			
Fuel Tank Capacity	2.7 L	2.5 L	3.6 L	3.6 L
Continuous Operating Time	Approx. 2 hrs 40 min	Approx. 2 hrs	Approx. 2 hrs 30 min	Approx. 2 hrs 10 min
Starting Method	Recoil starter			
Standard Accessories	1 Strainer, 2 Hose Couplings, 3 Hose Bands, 1 Engine Tool Set			
Gross Weight	27 kg	25 kg	34 kg	35 kg
Dimensions LxWxH (mm)	500 x 395 x 440	493 x 377 x 420	540 x 412 x 480	530 x 423 x 488
Packing Unit	1			



HIGH PRESSURE

Suitable for Sprinkler System & Fire Fighting

- Compact & lightweight high pressure pump
- 3 ways delivery flange [2"×1, 1"×2] (SERM-50V)



SEM-50V



SEM-50V Image



SERM-50V

Specifications

	SEM-50V	SERM-50V
PUMP	Connection Dia	50 mm (2")
	Connection Thread	Outer Pipe Thread
	Total Head	50 m (164 ft)
	Delivery Volume	500 L/min (132 USG/min)
ENGINE	Max. Suction Head	8 m (26 ft)
	Type	Forced Air Cooled 4 Stroke Gasoline Engine
	Model	Mitsubishi GM 132 Hi-Revolution
	Exhaust Volume	126 cc
	Rated Output	2.1 kW (2.8 PS) / 3600 rpm
	Max. Output	2.9 kW (4.0 PS)
	Fuel	Automotive Unleaded Gasoline
	Fuel Tank Capacity	2.5 L (0.66 USG)
	Continuous Operating Time	Approx. 2 hrs
	Starting Method	Recoil Starter
Standard Accessories	1 Strainer 3 Hose Bands 1 Hose Coupling 1 Quick Coupling 1 Engine Tool	1 Strainer 3 Hose Bands (φ 60) 2 Hose Bands (φ 32) 1 Coupling Set (50 mm) 1 Closing Plate (50 mm) 2 Nipples (25 mm) 1 Quick Coupling 1 Engine Tool
	Gross Weight	28 kg
Dimensions LxWxH (mm)	520 × 412 × 455	
Packing Unit	1	

Performance Curve

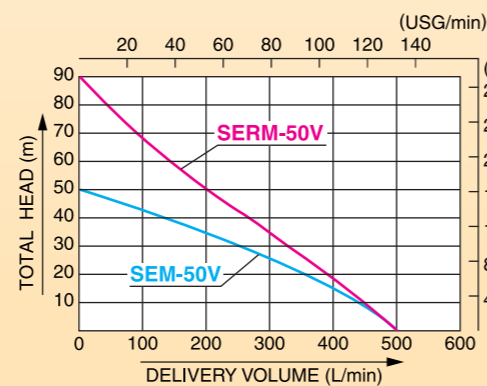

Pumps Suitable for Sprinkler System

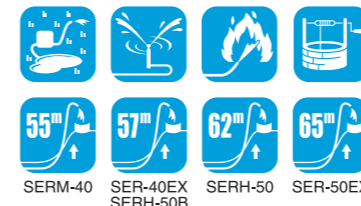

SER-50EX



SERH-50B



SERM-40

Performance Curve

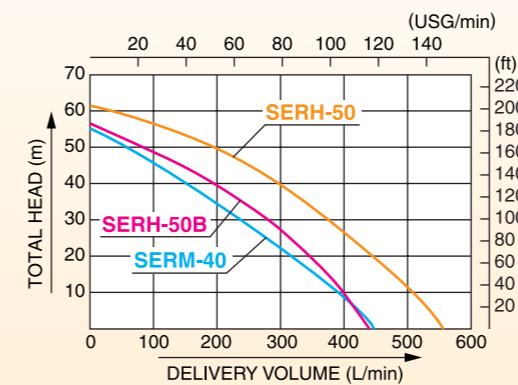
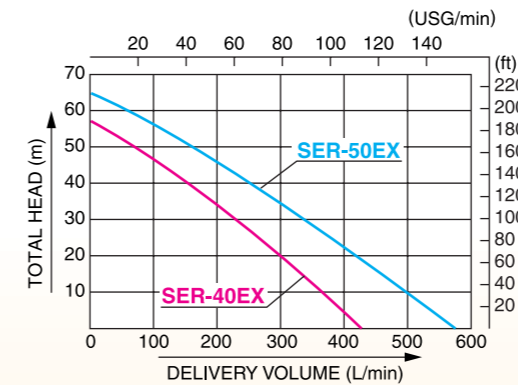

Specifications

	SER-40EX	SER-50EX	SERM-40	SERH-50B	SERH-50	
PUMP	Connection Dia	IN 50 mm (2") OUT 40 mm (1½")	IN 65 mm (2½") OUT 50 mm (2")	IN 50 mm (2") OUT 40 mm (1½")	IN 65 mm (2½") OUT 50 mm (2")	
	Connection Thread	Outer Pipe Thread				
	Total Head	57 m (187 ft)	65 m (213 ft)	55 m (180 ft)	57 m (187 ft)	62 m (203 ft)
	Delivery Volume	430 L/min (113 USG/min)	570 L/min (150 USG/min)	430 L/min (114 USG/min)	440 L/min (116 USG/min)	560 L/min (148 USG/min)
ENGINE	Max. Suction Head	8 m (26 ft)				
	Type	Forced Air Cooled 4 Stroke Gasoline Engine				
	Model	Robin EX17	Robin EX27	Mitsubishi GM182	Honda GX160	Honda GX240
	Exhaust Volume	169 cc	265 cc	181 cc	163 cc	242 cc
	Rated Output	2.9 kW (4.0 PS) / 3600 rpm	5.1 kW (7.0 PS) / 3600 rpm	3.3 kW (4.5 PS) / 3600 rpm	2.9 kW (3.9 PS) / 3600 rpm	4.4 kW (6.0 PS) / 3600 rpm
	Max. Output	4.2 kW (5.7 PS) / 4000 rpm	6.6 kW (9.0 PS) / 4000 rpm	4.4 kW (6.0 PS)	3.6 kW (4.9 PS) / 3600 rpm	5.3 kW (7.2 PS) / 3600 rpm
	Fuel	Automotive Unleaded Gasoline				
	Fuel Tank Capacity	3.6 L	6.1 L	3.8 L	3.1 L	5.3 L
	Continuous Operating Time	Approx. 2.5 hrs	Approx. 2 hrs 10 min	Approx. 3 hrs	Approx. 2 hrs 10 min	Approx. 2 hrs 30 min
	Starting Method	Recoil Starter				
Standard Accessories	1 Strainer, 3 Hose Bands, 2 Hose Couplings, 1 Engine Tool					
Gross Weight	35 kg	44 kg	38 kg	34 kg	46 kg	
Dimensions LxWxH (mm)	545 × 415 × 455	610 × 495 × 545	534 × 424 × 508	545 × 415 × 455	578 × 492 × 533	
Packing Unit	1					



PABOOL PUMPS

Pabool Pumps are Designed for Sprinkler System & General Irrigation



SU-40H



SU-50H

Performance Curve

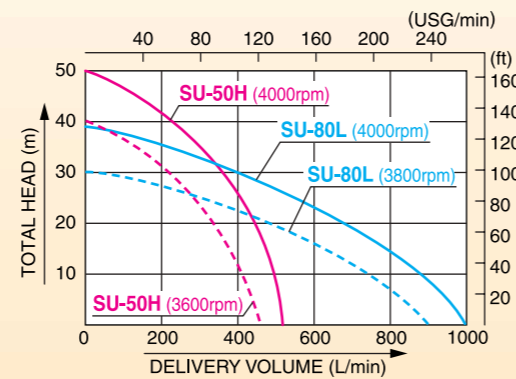
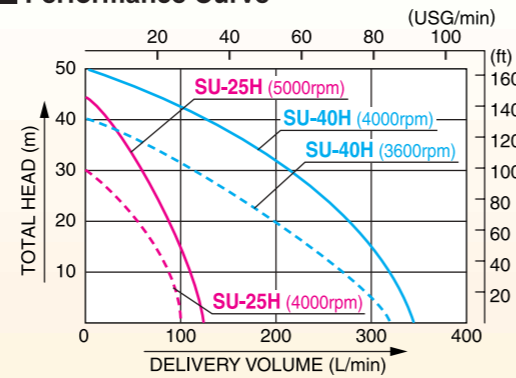

Specifications

Model	SU-25H		SU-40H		SU-50H		SU-80L	
Connection Dia	25 mm (1")		40 mm (1½")		50 mm (2")		80 mm (3")	
Connection Thread	Outer Pipe Thread							
Revolution	4000 rpm	5000 rpm	3600 rpm	4000 rpm	3600 rpm	4000 rpm	3600 rpm	4000 rpm
Total Head	29 m (95 ft)	45 m (147 ft)	40 m (131 ft)	50 m (164 ft)	40 m (131 ft)	50 m (164 ft)	30 m (98 ft)	38 m (124 ft)
Delivery Volume	96 L/min (25 USG/min)	120 L/min (31 USG/min)	315 L/min (83 USG/min)	350 L/min (92 USG/min)	450 L/min (118 USG/min)	500 L/min (132 USG/min)	900 L/min (237 USG/min)	1000 L/min (264 USG/min)
Output	1.5 kW (2 PS)	2.2 kW (3 PS)	2.2 kW (3 PS)	3.7 kW (5 PS)	3.7 kW (5 PS)	5.5 kW (7.5 PS)	5.5 kW (7.5 PS)	7.5 kW (10 PS)
Standard Accessories	1 Strainer, 2 Couplings, 3 Hose Bands							
Net Weight	7.5 kg		12 kg		14.5 kg		7.5 kg	
Gross Weight	35 kg		24 kg		32 kg		41 kg	
Dimensions LxWxH (mm)	713 x 483 x 250		384 x 469 x 284		397 x 526 x 295		597 x 465 x 367	
Packing Unit	4		2		2		2	

Powerful Pressure & Enhanced Durability



SUR-25V



SU-50V

Double Life Span Durability

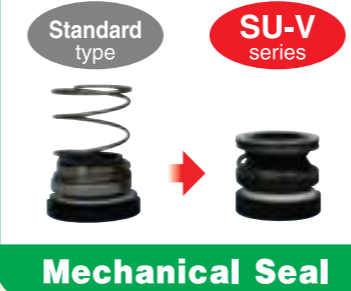

Mechanical Seal

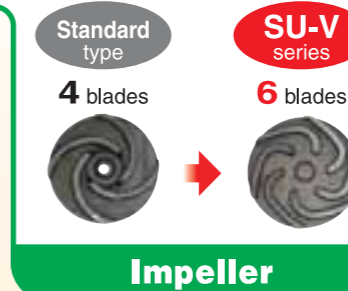

Impeller

Performance Curve

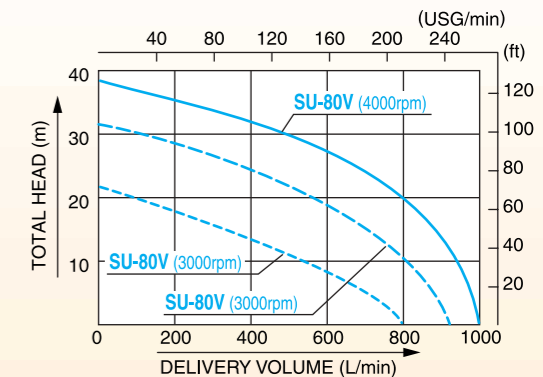
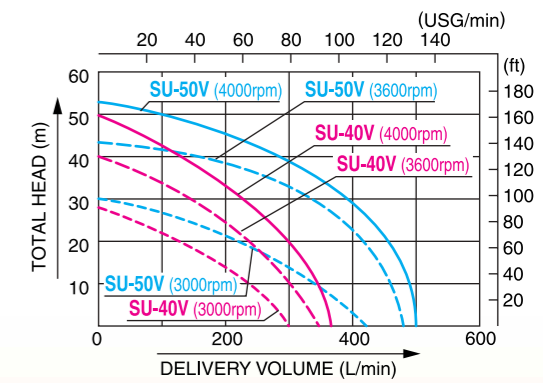
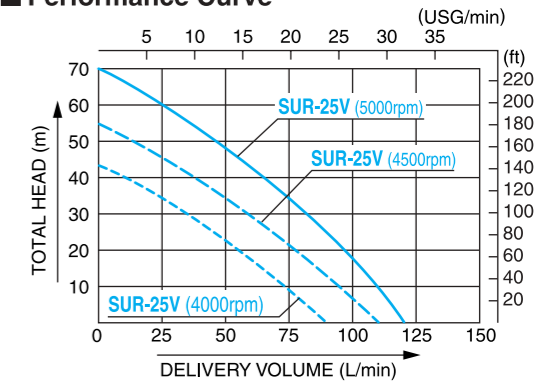

Specifications

Model	SUR-25V			SU-40V			SU-50V			SU-80V		
Connection Dia	25 mm (1")			40 mm (1½")			50 mm (2")			80 mm (3")		
Connection Thread	Outer Pipe Thread											
Revolution	4000 rpm	4500 rpm	5000 rpm	3000 rpm	3600 rpm	4000 rpm	3000 rpm	3600 rpm	4000 rpm	3000 rpm	3600 rpm	4000 rpm
Total Head	43 m (141 ft)	55 m (180 ft)	70 m (229 ft)	28 m (91 ft)	40 m (131 ft)	50 m (164 ft)	30 m (98 ft)	42 m (137 ft)	53 m (173 ft)	21 m (68 ft)	31 m (101 ft)	38 m (124 ft)
Delivery Volume	90 L/min (23 USG/min)	110 L/min (29 USG/min)	120 L/min (31 USG/min)	300 L/min (79 USG/min)	350 L/min (92 USG/min)	370 L/min (97 USG/min)	430 L/min (113 USG/min)	480 L/min (126 USG/min)	500 L/min (132 USG/min)	800 L/min (211 USG/min)	920 L/min (243 USG/min)	1000 L/min (264 USG/min)
Max. Suction Head	8 m (26 ft)			7 m (23 ft)	8 m (26 ft)		7 m (23 ft)	8 m (26 ft)			7 m (23 ft)	8 m (26 ft)
Output	1.5 kW (2 PS)	2.2 kW (3 PS)	2.8 kW (3.7 PS)	1.5 kW (2 PS)	2.2 kW (3 PS)	3.7 kW (5 PS)	2.2 kW (3 PS)	3.7 kW (5 PS)	5.5 kW (7.5 PS)	3.7 kW (5 PS)	5.5 kW (7.5 PS)	7.5 kW (10 PS)
Standard Accessories	1 Strainer, 2 Couplings, 3 Hose Bands											
Gross Weight	14 kg			13 kg			16 kg			22 kg		
Dimensions LxWxH (mm)	370 x 222 x 255			370 x 222 x 255			402 x 260 x 295			444 x 287 x 393		
Packing Unit	1											

Chart Shows Co-relation Between Motor Rotation and Pulley Diameter

Hz	Model Revolution	SUR-25V					
		4000		4500		5000	
	Motor Poles (Revolution)	mm	inch	mm	inch	mm	inch
50	2P (2880 rpm)	89	3½	99	4	109	4½
	4P (1430 rpm)	169	6½	209	8	233	9
	6P (960 rpm)	259	10	309	12	324	13
60	2P (2880 rpm)	74	3	84	3½	94	4
	4P (1430 rpm)	149	6	169	6½	189	8
	6P (960 rpm)	209	8	259	10	289	11

Hz	Model Revolution	SU-40V • SU-50V • SU-80V					
		3000		3600		4000	
	Motor Poles (Revolution)	mm	inch	mm	inch	mm	inch
50	2P (2880 rpm)	81	3½	96	4	106	4½
	4P (1430 rpm)	161	6½	191	8	211	9
	6P (960 rpm)	235	9	291	12	326	13
60	2P (2880 rpm)	66	2½	81	3½	91	3½
	4P (1430 rpm)	129	5	161	6½	181	8
	6P (960 rpm)	191	8	235	9	261	10



POLYETHYLENE PUMP BODY

For Seawater, Chemicals

- Superior material used.
 - PET (Polyethylene Terephthalate) for pump casing, impeller and volute casing.
 - EPDM and Carbon Ceramic for mechanical seal.
 - SUS for all bolts and washers.
- Powered by strong and durable engine.



PGH-50



PGM-50

Specifications

	Model	PGH-50	PGM-50
PUMP	Connection Dia	50 mm (2")	
	Connection Thread	Outer Pipe Thread	
	Total Head	26 m (85 ft)	21 m (68 ft)
	Max. Suction Head	8 m (26 ft)	
	Delivery Volume	560 L/min (148 USG/min)	540 L/min (142 USG/min)
ENGINE	Material for Mechanical Seal	Ceramic Carbon	
	Max. Pressure	0.26 MPa	0.21 MPa
	Type	Forced Air Cooling 4 Stroke Gasoline Engine	
	Model	Honda GX120	Mitsubishi GM132
	Exhaust Volume	118 cc	126 cc
	Rated Output	2.1 kW (2.9 PS) / 3600 rpm	2.1 kW (2.8 PS) / 3600 rpm
	Max. Output	2.6 kW (3.5 PS) / 3600 rpm	2.9 kW (4.0 PS)
	Fuel	Automotive Unleaded Gasoline	
	Fuel Tank Capacity	2.5 L	
	Continuous Operating Time	Approx. 2 hrs	Approx. 2.5 hrs
Starting Method	Recoil Starter		
Standard Accessories	2 Nipples, 1 Engine Tool Set		
Gross Weight	22 kg	25 kg	
Dimensions LxWxH (mm)	520 x 428 x 448	511 x 407 x 439	
Packing Unit	1		

Performance Curve

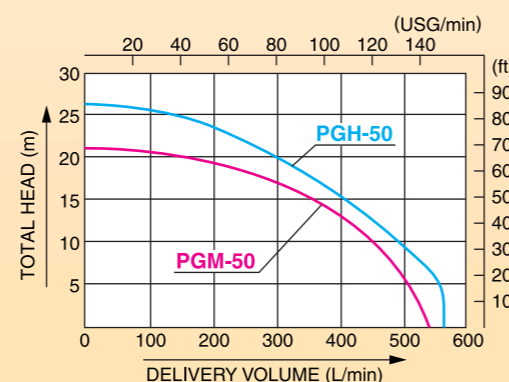

Long Life & Quiet for Home Use

- Thermal protector cuts off circuit in case of overload during operation.
- Effective motor cooling system.

Performance Curve

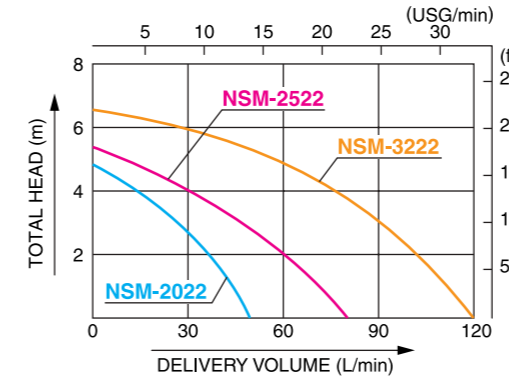

NSM-2522

"FULL TIME PONDY" Designed for Continuous Operation

- Anti-corrosion stainless steel (SUS 316L) is used for motor shaft.

Performance Curve

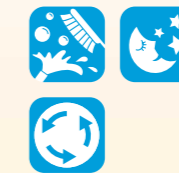
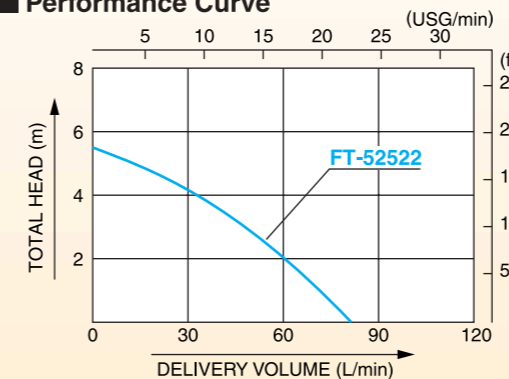

FT-52522

Specifications

	Model	NSM-2022	NSM-2522	NSM-3222	FT-52522	
PUMP	Connection Dia	20 mm (3/4")	25 mm (1")	32 mm (1 1/4")	25 mm (1")	
	Total Head	4.8 m (15 ft)	5.5 m (18 ft)	6.5 m (21 ft)	5.5 m (18 ft)	
	Delivery Volume	50 L/min (13 USG/min)	80 L/min (21 USG/min)	120 L/min (31 USG/min)	80 L/min (21 USG/min)	
	Voltage	AC 220 V				
MOTOR	Frequency	50 Hz / 60 Hz				
	Rated Current	0.7 A	1.0 A	1.2 A	1.25 A	
	Output	48 W	100 W	150 W	100 W	
	Consumption				220 W	
	Revolution	2800 rpm (50 Hz), 3200 rpm (60 Hz)			2800 rpm	
	Rating	Continuous				
	Motor Type	Condenser Induction Motor				
	Power Cord	4 m (13 ft)		5 m (16 ft)	4 m (13 ft)	
	Standard Accessories		1 Coupling Set (φ20) 1 Hose Nipple (φ15) 1 Hose Band (φ15) 1 Hose Band (φ20)	1 Coupling Set (φ25) 1 Hose Nipple (φ20) 1 Hose Band (φ20) 1 Hose Band (φ25)	1 Coupling Set (φ32) 1 Hose Nipple (φ25) 1 Hose Band (φ25) 1 Hose Band (φ32)	1 Hose Coupling (φ15) 1 Hose Coupling (φ20) 1 Hose Coupling (φ25) 1 Hose Band (φ15) 1 Hose Band (φ20) 1 Hose Band (φ25)
		Gross Weight	19 kg	17 kg	21 kg	5 kg
Dimensions LxWxH (mm)		430 x 293 x 335	325 x 325 x 365	355 x 355 x 363	170 x 170 x 405	
Packing Unit		6		4	1	



HEAVY DUTY SUBMERSIBLE PUMPS

Powerful Pumps for Heavy Duties

- Double mechanical seals in oil chamber filled with liquid paraffin prevents damage from dry running.
- Liquid paraffin is used in the shaft seal. Water is not contaminated even in case of oil leakage.
- Thermal protector cuts off circuit in case of overload during operation.



PB-55011



Effective Motor Cooling System

Water is channeled through the outer wall to cool the motor for maximum endurance.

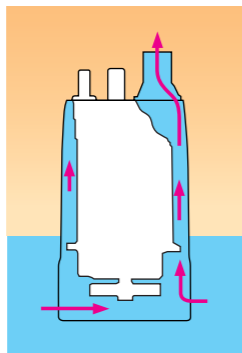

Specifications

Model	PB-55011	PB-55022	PB-55022A	PB-65011
PUMP	Connection Dia	50 mm (2")		
	Total Head	10 m (32 ft)		
	Delivery Volume	290 L/min (76 USG/min)		
	Voltage	AC 110 V	AC 220 V	AC 110 V
MOTOR	Frequency	50 Hz		60 Hz
	Rated Current	7.3 A	3.6 A	8.7 A
	Output	400 W		
	Consumption	760 W	680 W	750 W
	Revolution	2900 rpm		3400 rpm
	Model	Induction Motor		
	Power Cord	10 m (32 ft) [CE Model] / 6 m (19 ft)		6 m (19 ft)
Standard Accessories	1 Rope (5 m), 1 Hose Band			
Gross Weight	32 kg		65 kg	
Dimensions LxWxH (mm)	533 x 270 x 509		533x533x509	
Packing Unit	2		4	

Performance Curve

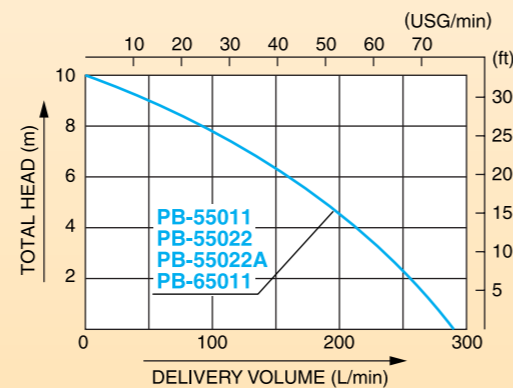

*Starting current is three times higher than rated current.

Great Durability



PX-55022

For Residual Water Up to 1 mm

- Designed for application in narrow access drainage especially in manhole or bottom pit.



PXL-52522

Applications

- Drainage of underground water
- Disposal of residual water from roof tank of buildings, swimming pools, etc.
- Construction site
- Pond / Aquarium usage
- Irrigation
- Home / Domestic application

Performance Curve

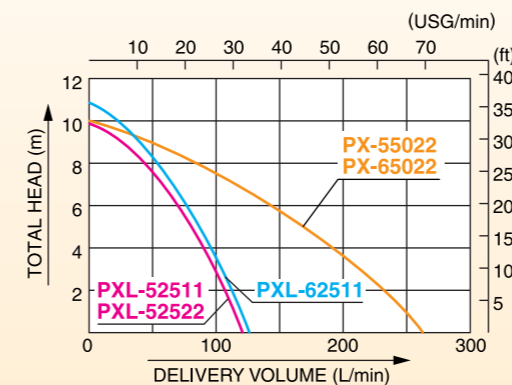

*Starting current is three times higher than rated current.

Invertible Delivery Flange

Just 2 bolts delivery flange is inverted



Specifications

Model	PX-55011	PX-55022	PXL-52511	PXL-52522	PXL-62511	
PUMP	Connection Dia	50 mm (2")		25 mm (1")		
	Total Head	10 m (32 ft)			11 m (36 ft)	
MOTOR	Delivery Volume	260 L/min (68 USG/min)		120 L/min (31 USG/min)	125 L/min (33 USG/min)	
	Voltage	AC 110 V	AC 220 V	AC 110 V	AC 220 V	AC 110 V
MOTOR	Frequency	50 Hz			60 Hz	
	Rated Current	6.5 A	3.2 A	6.0 A	2.9 A	6.8 A
	Output	400 W				
	Consumption	580 W	620 W	590 W	540 W	680 W
	Revolution	3400 rpm		2900 rpm		3400 rpm
	Model	Condenser Induction Motor				
	Power Cord	5 m (16 ft)				
Standard Accessories	1 Hose Band, 1 Rope (5 m)		1 Hose Band, 1 Hose Nipple, 1 Coupling, 1 Coupling Packing, 1 Rope (5 m)			
Gross Weight	25 kg		28 kg			
Dimensions LxWxH (mm)	258 x 500 x 424		530 x 278 x 452			
Packing Unit			2			

Light & Durable

- Double mechanical seals using silicon carbide ensure durability and shaft protection.
- Thermal protector cuts off circuit in case of overload during operation.



PS-55022



PSA-55022

Automatic Float Switch

Best for Sewage Application

- Cast iron (FC) casing ensures resistance to sewage. (PKS)
- The built-in thermal protector cuts off circuit in case of overload during operation.
- Only 3 butterfly bolts and strainer can be detached for maintenance. (PKS)



PSK-53222



PKS-55022

Solids Available

Max. 10 mm

PSK-53222

Max. 15 mm

PKS-55022

Specifications

	Model	PS-55022	PSA-55022
PUMP	Connection Dia	50 mm (2")	
	Total Head	10 m (32 ft)	
	Delivery Volume	280 L/min (74 USG/min)	
	Voltage	AC 220 V	
MOTOR	Frequency	50 Hz	
	Rated Current	3.6 A	
	Output	400 W	
	Consumption	600 W	
	Revolution	3200 rpm	
	Rating	Continuous	
	Type	Induction Motor	
	Power Cord	6 m (19 ft)	
	Standard Accessories	1 Hose Band, 1 Rope (5 m)	
	Gross Weight	58 kg	65 kg
Dimensions LxWxH (mm)	460 x 460 x 442	495 x 495 x 505	
Packing Unit	4		

Performance Curve

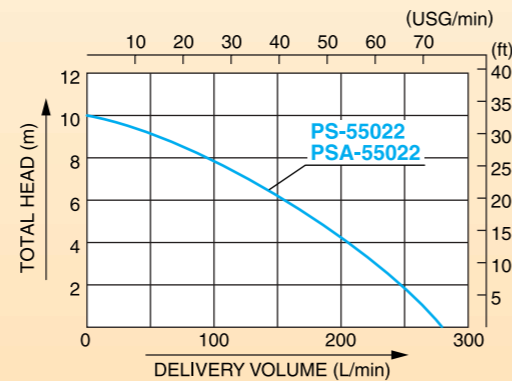

*Starting current is three times higher than rated current.

Specifications

	Model	PSK-53222	PKS-55022
PUMP	Connection Dia	32 mm (1 1/4")	50 mm (2")
	Total Head	6 m (19 ft)	10 m (32 ft)
	Delivery Volume	140 L/min (37 USG/min)	300 L/min (79 USG/min)
MOTOR	Voltage	AC 220 V	
	Frequency	50 Hz	
	Rated Current	1.4 A	4.0 A
	Output	150 W	400 W
	Consumption	305 W	704 W
	Revolution	2900 rpm	
	Rating	Continuous	
	Type	Induction Motor	
	Power Cord	4 m (13 ft)	6 m (19 ft)
	Standard Accessories	1 Hose Band, 1 Rope (5 m)	
Gross Weight	11 kg	70 kg	
Dimensions LxWxH (mm)	374 x 193 x 422	509 x 509 x 532	
Packing Unit	2	4	

Performance Curve

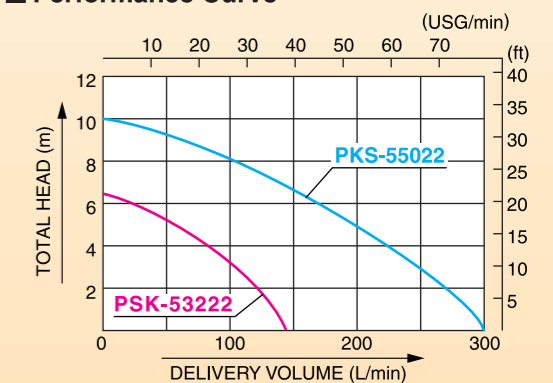

*Starting current is three times higher than rated current.



GENERATORS

KOSHIN Generators Fitted with AVR Featuring High Durability YAMAHA Engine

- **AVR (Automatic Voltage Regulator)**
KOSHIN's AVR regulates power output fluctuations to enable operation of sensitive electronic equipment.
- **Oil Warning System**
The system automatically stops the engine when the oil drops below a predetermined level.
- **Large Fuel Tank**
Large capacity fuel tank with oil fuel meter.
- **DC Output Capability**
Direct current output capability permits recharging of batteries.
- **Rugged Full-Frame**
Protects the generator from rough handling and damage.



GE-3000X



GE-7200XS

Examples of Application

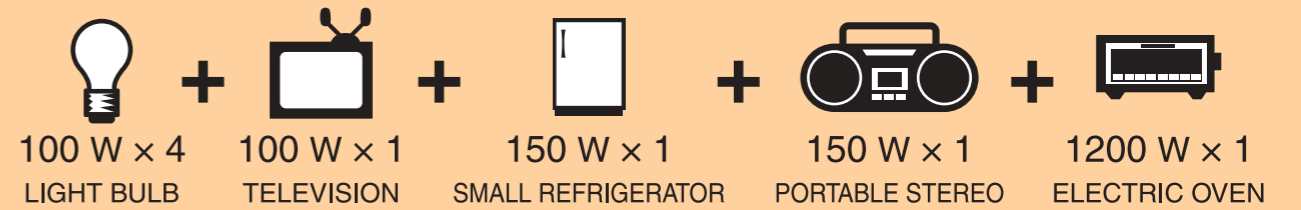

GE-3000X

2000 w



GE-7200XS

5000 w

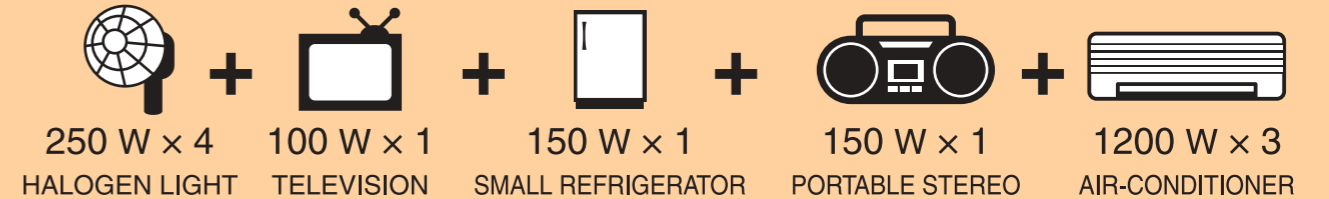

Specifications

Model		GE-3000X	GE-7200XS
Model		YAMAHA MZ175	YAMAHA MZ360
Type		Single Cylinder, Forced Air Cooling 4 Stroke Gasoline Engine	
Displacement		171 cc	357 cc
Rated Output		3.3 kW (4.5 PS) / 3600 rpm	7.1 kW (9.7 PS) / 3600 rpm
Max. Output		4.0 kW (5.5 PS) / 4000 rpm	8.8 kW (12.0 PS) / 4000 rpm
Ignition System		T.C.I. (Transistor Controlled Ignition)	
Fuel Tank Capacity		18 L	25 L
Operating Hours		16 hrs	9 hrs
Oil Capacity		600 cc	1100 cc
Sound Level		65 db(A) / 7 m	72 db(A) / 7 m
Starting Method		Recoil	Electric Start and Recoil
GENERATOR	AC Output	Rated (50 Hz) 2.0 KVA Max. (50 Hz) 2.4 KVA	5.0 KVA 6.1 KVA
	Rated Voltage	AC 220 V	
DC Output		12 V / 8.3 A	
Rated Power Factor (Cos φ)		1	
Features		AVR, Oil Warning System, Non-fuse Breaker	
Gross Weight		48 kg	93 kg
Dimensions LxWxH (mm)		605 x 450 x 495	705 x 555 x 570
Packing Unit		1	



GARDEN SPRAYERS

"Double Piston Method"

- "One hand operation lever"
Easy operation designed for spraying continuously or intermittently.
- 2-stage extendable nozzle 630 – 1135 mm.
- Safety valve with simple pressure gauge.
- Big funnel for easy pouring.



Specifications

Model	HS-503W	HS-703W
Tank Capacity	5 L	7 L
Hose Length	5 m (16 ft)	
Nozzle Type	2-Stage Extendable, 2-Head	
Total Extendable Length	63 – 113.5 cm (24" – 44")	
Operating Pressure Around Safety Valve	0.5 MPa (5 kgf/cm ²)	
Spraying Time	1-Head	21 min
	2-Head	31 min
Spray Area	10 min	15 min
	56 – 72.7 m ²	79 – 99 m ²
Gross Weight	14 kg	15 kg
Dimensions LxWxH (mm)	420 × 420 × 665	
Packing Unit	4	

Double Piston Method

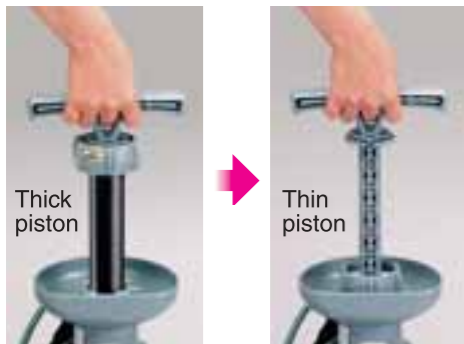

Powerful!

Light!

Switchable Nozzle



1 Head

2 Heads

Easy Operation Designed for Spraying Continuously or Intermittently by One Hand Operation Lever

- Safety valve prevents excessive pressure.



Economical

1-Head



HS-401C

Specifications

Model	HS-401C
Tank Capacity	4 L
Hose Length	2 m (6 ft)
Nozzle Type	1-Stage Extendable, 1-Head
Total Extendable Length	38 cm (14")
Operating Pressure around Safety Valve	0.4 MPa (4 kgf/cm ²)
Spraying Time	20 min
Spray Area	46 – 59 m ²
Jet Distance	6.5 m (21 ft)
Gross Weight	11.5 kg
Dimensions LxWxH (mm)	600 × 413 × 437
Packing Unit	6

"Garden Master" Powered by Dry Cell Battery

- Big tank opening for easy cleaning and refilling.
- Internally sloped bottom design ensures all liquids are used up.



2-Way Spray Shower / Sharp

For Herbicide Shower Nozzle included



3-Stage Extendable Nozzle

Specifications

Model	GT-3	GT-5
Tank Capacity	3 L	5 L
Hose Length	1.5 m (5 ft)	
Nozzle Type	3-Stage Extendable, 1-Head	
Total Extendable Length	43 – 100 cm (16" – 39")	
Battery	DC 1.5 V × 4 pcs	
Rating Voltage	4.8 V	
Battery Life	Approx. 70 L (18 USG) (Alkaline Battery) Approx. 30 L (8 USG) (Manganese Battery)	
Spray Volume	Approx. 240 ml/min (Shower Spray) Approx. 400 ml/min (Sharp Spray)	
Shower Spraying Time	13 min	21 min
Spray Angle	60 °	
Jet Distance	4 m (13 ft)	
Standard Accessories	1 Spout, 1 Herbicide Nozzle	
Gross Weight	8 kg	4.5 kg
Dimensions LxWxH (mm)	390 × 540 × 385	280 × 390 × 385
Packing Unit	4	2



GT-3

Fine Mist Sprayer with Tank

• Convenient hose reel attached.



φ5×100m Hose

5 Level Spraying Pressure

φ5×50m Hose

50L Tank

φ8.5×20m Hose
25L Tank



KV-ER100



KV-ER50 + TK-50N



TK-50N



MS-E2R25TH85

Convenient Caster for Mobility



Easy & Tidy Hose Coiling



Specifications

Model (Hose Dia)	MS-E2R25TH85 (φ8.5 mm)	KV-ER50 (φ5 mm)	KV-ER100 (φ5 mm)	TK-50N
Type	Double Piston Pump			
Max. Suction Head	8.6 L/min (2 USG/min)			
Delivery Volume	1.5 - 4.3 L/min	1.0 - 2.9 L/min	1.0 - 2.4 L/min	Length: 900 mm (40") Width: 575 mm (22") Height: 843 mm (34") Tank: 50 L (13 USG)
Max. Pressure	3.0 MPa (30 kgf/cm ²)			
Nozzle Head	Granular Type 2-Head Nozzle, Bubble Type 2-Head Nozzle Vertical			
Delivery Hose	φ8.5 × 20 m (66 ft)	φ5 × 50 m (164 ft) (With Reel)	φ5 × 100 m (328 ft) (With Reel)	
Type	Forced Air Cooling 2 Stroke Gasoline Engine	Forced Air Cooling 4 Stroke Gasoline Engine		
Model	Robin EC025	Robin EH025		
Exhaust Volume	24.5 cc			
Rated Output	0.55 kW (0.7 PS) / 6000 rpm	0.55 kW (0.7 PS) / 7000 rpm		
Max. Output	0.88 kW (1.1 PS) / 7000 rpm	0.81 kW (1.1 PS) / 7000 rpm		
Fuel	2 Stroke Mixed Gas and Oil	Automotive Unleaded Gasoline		
Fuel Tank Capacity	0.6 L	0.5 L		
Continuous Operating Time	Approx. 40 min			
Starting Method	Recoil Starter			
Gross Weight	25.5 kg	29.5 kg	24 kg	
Dimensions LxWxH (mm)	705 × 490 × 635	710 × 470 × 450	875 × 590 × 595	
Packing Unit	1			

"GROUND MASTER" Backpack Manual Sprayer

Specifications

Model	RM-10	RM-15	RM-18
Tank Capacity	10 L	15 L	18 L
Pump	Piston Pump		
Max. Pressure	0.5 MPa (5 kgf/cm ²)		
Nozzle Length	46 cm	62 - 109 cm	
Spray Volume [Common Pressure] [0.3 MPa (3 kgf/cm ²)]	Bubble Type Herbicide Nozzle : 600 mL/min Granular Type Herbicide Nozzle : 700 mL/min 2-Head Nozzle (Shower Spray) : 670 mL/min (Sharp Spray) : 1260 mL/min		
Spray Pressure	0.3 MPa (3 kgf/cm ²)		
Connection	G ¹ / ₄ (PF ¹ / ₄)		
Standard Accessories	1 Bubble Type Herbicide Nozzle with Cover, 1 Granular Type Herbicide Nozzle, 1 2-Head Nozzle, 1 Measuring Cup, 1 Nozzle Grip, 1 Nozzle Pipe		
Net Weight	4.7 kg	5.1 kg	5.4 kg
Dimensions LxWxH (mm)	435 × 465 × 660	435 × 565 × 679	405 × 265 × 735
Packing Unit	2		



RM-18

Standard Accessories

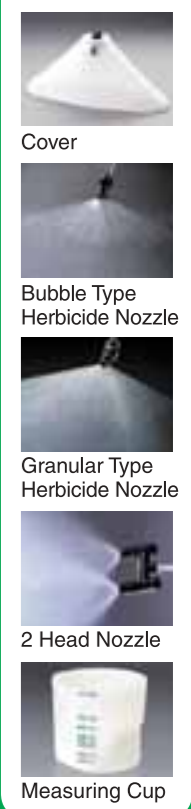

Cover

Bubble Type Herbicide Nozzle

Granular Type Herbicide Nozzle

2 Head Nozzle

Measuring Cup

Easy to Change & Durable Battery

- Battery power indicator included.
- Buzzer will sound when recharging is required.



KK-10V

Specifications

Model	KK-10V	KK-10VL	KK-15V
Tank Capacity	10 L		
Pump	Ceramic Gear Pump		
Motor	DC 12 V		
Max. Pressure	0.3 MPa (3 kgf/cm ²)		
Spray Volume	2-Head Nozzle : 0.7 L/min [Spray Pressure: 0.27 MPa (2.7 kgf/cm ²)] Bubble Type Herbicides Nozzle : 0.5 L/min [Spray Pressure: 0.28 MPa (2.8 kgf/cm ²)] Granular Type Herbicides Nozzle : 0.8 L/min [Spray Pressure: 0.27 MPa (2.7 kgf/cm ²)]		
Operating Time	1 hr 20 min		2 hrs 30 min
Current	Approx. 1.8 A		
Battery	Ni-Cad Battery, 2500 mAh	Ni-Cad Battery, 5000 mAh	
Battery Charger	Hi-Charging AC 100 V, 50 / 60 Hz		
Standard Rechargeable Hours	1 hr 20 min	2 hrs 30 min	
Connection	G ¹ / ₄ (PF ¹ / ₄)		
Fuse	5 A		
Standard Accessories	1 Battery Charger, 1 Bubble Type Herbicide Nozzle with Cover, 1 Granular Type Herbicide Nozzle, 1 2-Head Nozzle, 1 Measuring Cup, 1 Syringe, 1 Nozzle Grip, 1 Nozzle Pipe		
Gross Weight	4.7 kg	5.5 kg	5.8 kg
Packing Unit	1		

FOR INDUSTRIAL APPLICATION

"GEAR PUMP" GL Series for Low Viscosity Oil

- Safety by-pass function protects pump.

Applications

- Kerosene
- Machine Oil
- Heavy Oil
- Light Oil



GL-25-5

* Must not be used for gasoline.

Performance Curve

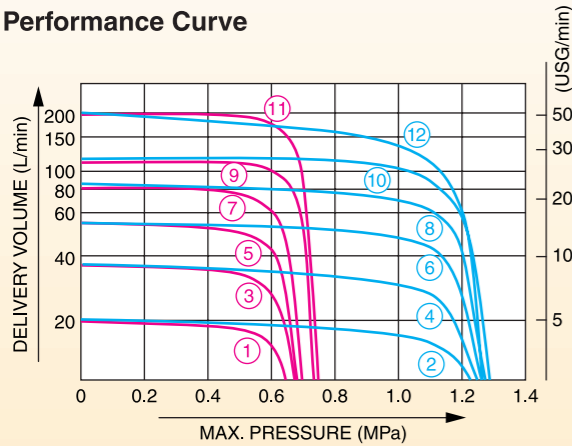

Specifications

Model	GL-13-5	GL-13-10	GL-20-5	GL-20-10	GL-25-5	GL-25-10	GL-32-5	GL-32-10	GL-40-5	GL-40-10	GL-50-5	GL-50-10
Performance Curve No.	①	②	③	④	⑤	⑥	⑦	⑧	⑨	⑩	⑪	⑫
Connection Dia	13 mm (1/2")	20 mm (3/4")	25 mm (1")	32 mm (1 1/4")	40 mm (1 1/2")	50 mm (2")						
Power	0.4 kW	0.75 kW	0.75 kW	1.5 kW	1.5 kW	2.2 kW	2.2 kW	3.7 kW	2.2 kW	5.5 kW	3.7 kW	7.5 kW
Poles	4 P						6 P					
Max. Pressure	0.5 MPa (5 kgf/cm ²)	1 MPa (10 kgf/cm ²)	0.5 MPa (5 kgf/cm ²)	1 MPa (10 kgf/cm ²)	0.5 MPa (5 kgf/cm ²)	1 MPa (10 kgf/cm ²)	0.5 MPa (5 kgf/cm ²)	1 MPa (10 kgf/cm ²)	0.5 MPa (5 kgf/cm ²)	1 MPa (10 kgf/cm ²)	0.5 MPa (5 kgf/cm ²)	1 MPa (10 kgf/cm ²)
Delivery Volume	60 Hz (1720 rpm)	20 L/min (5 USG/min)	35 L/min (9 USG/min)	55 L/min (14 USG/min)	85 L/min (22 USG/min)	123 L/min (32 USG/min)	200 L/min (52 USG/min)					
	50 Hz (1450 rpm)	17 L/min (4 USG/min)	29 L/min (7 USG/min)	46 L/min (12 USG/min)	71 L/min (18 USG/min)	100 L/min (26 USG/min)	165 L/min (43 USG/min)					
Coupling	ZDC						JIS					
Pump Shaft Dia	φ 18 mm						φ 22 mm					
Gross Weight	8 kg	8.5 kg	9 kg	11 kg	21 kg	23 kg						
Dimensions LxWxH (mm)	234 × 160 × 170	234 × 160 × 170	234 × 160 × 170	317 × 160 × 170	328 × 268 × 235	328 × 268 × 235						
Packing Unit	1											

"CHANGE MASTER" Oil Change Pumps

- Powerful pump transfers high viscosity oil. (Up to 800 cst)
- Highly recommended for motor oil change.
- Safety by-pass valve protects pump.

Applications

- Motor Oil
- Machine Oil
- Heavy Oil
- Light Oil



*Must not be used for gasoline.



GM-2524H

Specifications

Model	GM-2524H	
PUMP	Dia of Hose Inlet	25 mm (1")
	Dia of Hose Outlet	20 mm (3/4")
	Connection Thread	Inner Pipe Thread
	Max. Delivery Pressure	0.2 MPa (2 kgf/cm ²)
	Delivery Volume	20 L/min (5 USG/min)
	Applicable Viscosity	800 cst
MOTOR	Voltage	DC 24 V
	Rated Current	16 A
	Output	200 W
	Revolution	6200 rpm
	Rating	25 min
	Power Cord	5 m (16 ft)
Gross Weight	10 kg	
Dimensions LxWxH (mm)	320 × 188 × 268	
Packing Unit	1	

E-type Hose Set for GM Pumps

- Suction Dia: 25 mm × 2 m
- Delivery Dia: 20 mm × 2 m
- 1 Nozzle, 1 Strainer, 2 Joints



Performance Curve

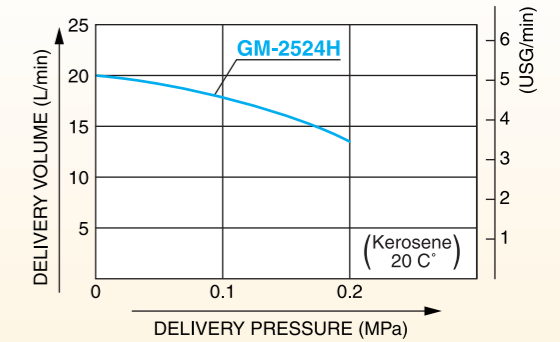

"FS PUMP" Self-priming Pump for Low Viscosity Oil



* Must not be used for gasoline.

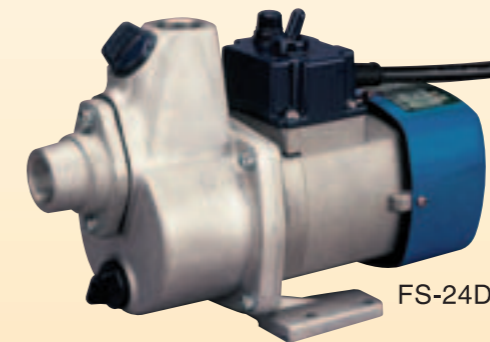

FS-24D

Specifications

Model	FS-12D	FS-24D
Connection Dia	20 mm (3/4")	
Total Head	7 m (23 ft)	9 m (30 ft)
Delivery Volume	40 L/min (10 USG/min)	50 L/min (13 USG/min)
Voltage	DC 12 V	DC 24 V
Rated Current	15 A	8 A
Output	80 W	90 W
Revolution	7300 rpm	
Gross Weight	20 kg	
Dimensions LxWxH (mm)	790 × 315 × 240	
Packing Unit	5	

T-type Hose Set for FS Pumps

- Suction Dia: 20 mm × 2 m
- Delivery Dia: 20 mm × 2 m
- 1 Nozzle, 1 Strainer, 2 Quick Joints



Performance Curve

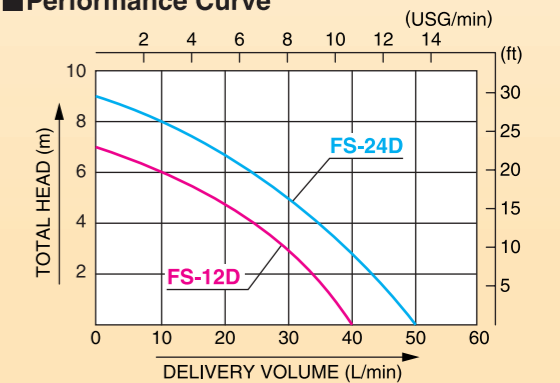

"GEAR PUMPS"

Suitable for Water, Oil & Various Liquids Applications



GB-13
GC-13



GB-25
GC-25

Applications (GB)

- Water
- Sea water
- Weak acids
- Various chemicals
- Coal tar



Applications (GC)

- Kerosene
- Light oil
- Machine oil
- Heavy oil



Performance Curve

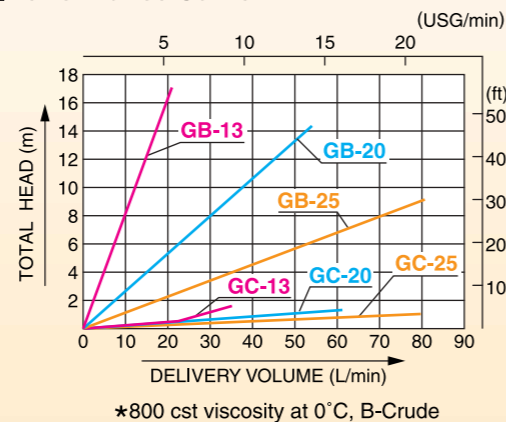

Specifications

Model	GC-13	GB-13	GC-20	GB-20	GC-25	GB-25
Gear Material	GC: Cast Iron / GB: Brass					
Connection Dia	13 mm (1/2")		20 mm (3/4")		25 mm (1")	
Delivery Volume	Revolution: 200 rpm	10 L/min (2 USG/min)	18 L/min (4 USG/min)	27 L/min (7 USG/min)	32 L/min (8 USG/min)	55 L/min (14 USG/min)
	Revolution: 400 rpm	21 L/min (5 USG/min)	37 L/min (9 USG/min)	55 L/min (14 USG/min)	83 L/min (22 USG/min)	
	Revolution: 600 rpm	32 L/min (8 USG/min)	56 L/min (14 USG/min)	83 L/min (22 USG/min)		
Delivery Pressure	0.1 – 0.3 MPa (1 – 3 kg/cm ²)					
Syphoning Factor	3 m (10 ft)					
Power	200 W		400 W		750 W	
Pulley	125 × A1		150 × A1		200 × A1	
Gross Weight	18 kg	17 kg	26 kg	26 kg	26 kg	26 kg
Dimensions LxWxH (mm)	401 × 246 × 182		492 × 262 × 194		265 × 265 × 275	
Packing Unit	4			2		

"PACO-PET"

Plastic Syphon Pumps

Applications

- Kerosene
- Gasoline
- Diesel oil
- Solvent
- Water (Non-potable)

Specifications

Model	PH-10	PH-20
Delivery Volume	6.7 L/min (1 USG/min)	11.5 L/min (3 USG/min)
Pump Length	690 mm (27")	840 mm (33")
Gross Weight	11.5 kg	10.5 kg
Dimensions LxWxH (mm)	690 × 340 × 618	810 × 355 × 510
Packing Unit	120	60



"MAMA AUTO"

Plastic Pumps Operated by Dry Cell Battery

Applications

- Kerosene

No Overflow Trouble

Type AA
2 Batteries (Not Included)

Big Switch for Easy ON/OFF Control

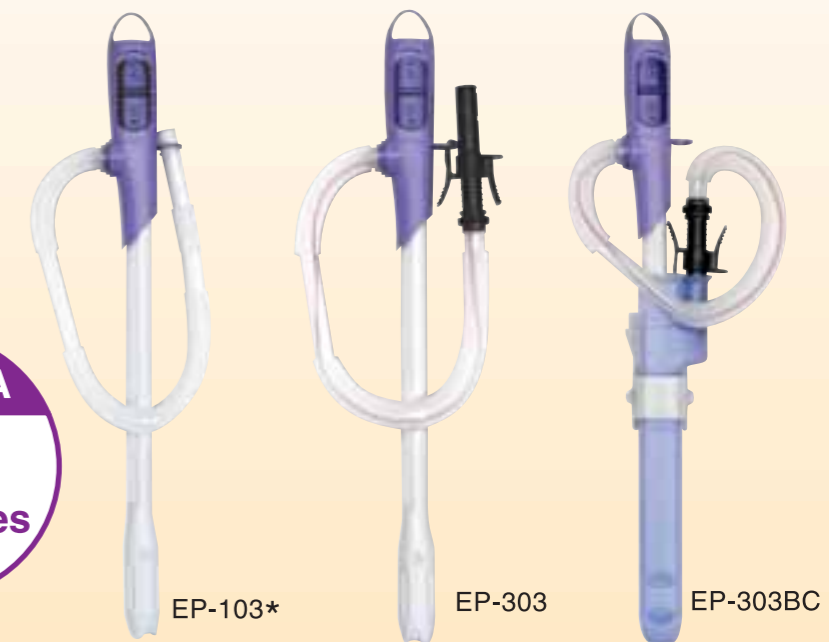

Specifications

Model	EP-103	EP-303	EP-303BC
Applications	Kerosene		
Delivery Volume	10 L/min (2 USG/min)		
Pump Length	547 mm (21")		
Case Length	—	—	435 mm (17")
Power	2 × 1.5 V AA Batteries (Not Included)		
Gross Weight	6 kg	7 kg	6 kg
Dimensions LxWxH (mm)	300 × 315 × 585		290 × 280 × 615
Packing Unit	20	—	12

*EP-103 does not have auto stop function.

Suitable for Transferring Kerosene & Diesel

- 10 minutes to empty 200 L drum.
- Easy to use gun nozzle.
- Suction pipe with mesh strainer.

Applications

- Kerosene
- Diesel



Specifications

Model	FP-25
Connection Dia	25 mm (1")
Total Head	3.5 m (11 ft)
Delivery Volume	20 L/min (5 USG/min)
Voltage	AC 100 V AC 220 V
Frequency	50 Hz / 60 Hz
Power Code	4 m (13 ft)
Delivery Hose	1.5 m (4.9 ft)
Gross Weight	6 kg
Dimensions LxWxH (mm)	290 x 280 x 615
Packing Unit	1



FP-25

"HAND ROTARY PUMP" Compact in Design & Light Weight

- Applicable for oil from high to low viscosity.

Applications

- Machine oil
- Heavy fuel oil A
- Kerosene
- Diesel



*Oil temperature is over 10°C

Specifications

Model	SB-20	SB-25
Delivery Volume	20 L (5 USG/min) / 105 Rotations	20 L (5 USG/min) / 72 Rotations
Impeller Material	PPS	
Delivery Hose (mm)	20 x 1100 (¾" x 43")	25 x 1280 (1" x 50")
Gross Weight	24 kg	25 kg
Dimensions LxWxH (mm)	1065 x 245 x 145	1085 x 202 x 225
Packing Unit	6	4



SB-25

For High Viscosity Oil (Up to 2000 cst)

- Specially designed for dispensing oil at service stations.

Applications

- High viscosity oil



SO-25

Specifications

Model	SO-25
Delivery Volume	0.5 L/Stroke (0.1 USG/min)
Pump Length	1380 mm (54")
Suction Pipe Dia	32 x 1038 (1¼" x 40")
Gross Weight	55 kg
Dimensions LxWxH (mm)	1080 x 398 x 220
Packing Unit	5

"HIGH LITER PUMP" High Volume

- Delivers 1 L per rotation.
- Mesh strainer can filter fine dust.
- Applicable for low viscosity oil.

Applications

- Diesel
 - Kerosene,
 - Spindle oil
 - Heavy fuel oil A
- *Oil temperature is over 10°C



LP-32

Specifications

Model	LP-32
Delivery Volume	1 L / 1 Rotation, (Normal Use) 100 L/min (26 USG/min)
Suction Pipe	32 x 956 (1¼" x 37")
Delivery Hose (mm)	32 x 1280 (1¼" x 50")
Strainer	#60 with Mesh, Polyethylene
Gross Weight	38 kg
Dimensions LxWxH (mm)	1137 x 252 x 295
Packing Unit	5

"BIG AUTO PUMP" Light weight & Economical to Use

- Made from strong plastics.

Applications (PP-25)

- Dispensing small volumes of liquid
- Heavy fuel oil B
- Kerosene
- Diesel
- Water
- Wine

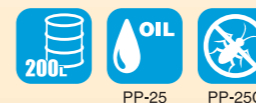

(PP-25C)

- Solvent



PP-25

PP-25C

Specifications

Model	PP-25	PP-25C
Delivery Volume	20 L/min (5 USG/min)	
Material	Polyethylene	
Pump Length	1190 mm (47")	
Suction Pipe (mm)	(Inside Dia) 22 x 875 (0.86" x 34")	
Delivery Hose (mm)	(Inside Dia) 20 x 1180 (¾" x 46")	
Gross Weight	11 kg	
Dimensions LxWxH (mm)	1237 x 435 x 257	
Packing Unit	20	

PP-25C Chemical Compatibility Rating Information

Rating Scale		
○	No Effect	
△	Moderate Effect	
×	Not Recommended	
N	Information Not Available	
Chemical (100% concentration unless noted)	Rating	
A Acetone	×	
Ammonium Hydroxide	N	
C Chlorine	○	
D Deionized Water	△	
Diesel Fuel	○	
E Ethanol	○	
G Gasoline	△	
Glycol	N	
H Hydrochloric Acid (20%)	○	
Hydrochloric Acid (37%)	○	
Hydrochloric Acid (100%)	○	
I Isopropyl Alcohol	N	
K Kerosene	○	
L Lacquer Thinner	×	
M Methanol	○	
Methyl Chloride	×	
Methyl Ethyl Ketone	×	
Mineral Spirits	N	
Motor Oil	○	
N Nitric Acid (20%)	△	
Nitric Acid (50%)	△	
Nitric Acid (Concentrated)	△	
O Oil, Hydraulic	○	
P Paint	×	
Phosphoric Acid (< 40%)	○	
Phosphoric Acid (≥ 40%)	○	
S Salt Water	○	
Seawater	○	
Sodium Hypochlorite	N	
Sodium Hydroxide (20%)	N	
Sodium Hydroxide (50%)	N	
Sodium Hydroxide (80%)	N	
Sulfuric Acid (<10%)	○	
Sulfuric Acid (10-75%)	○	
Sulfuric Acid (75-100%)	○	
W Water	○	
X Xylene	△	

Powerful "FILL PUMP" Only 2 Minutes to Empty 200 L Drum (FR-200)

- Two stage system of axial flow vane and spiral vane result in an excellent flow rate.

■ Performance Curve

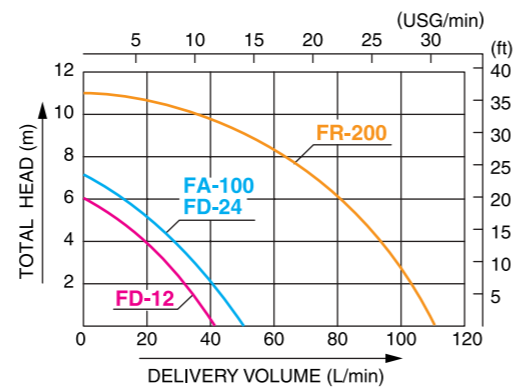

■ Applications

- High to low viscosity oil
- Machine oil
- Heavy fuel oil B
- Kerosene
- Diesel

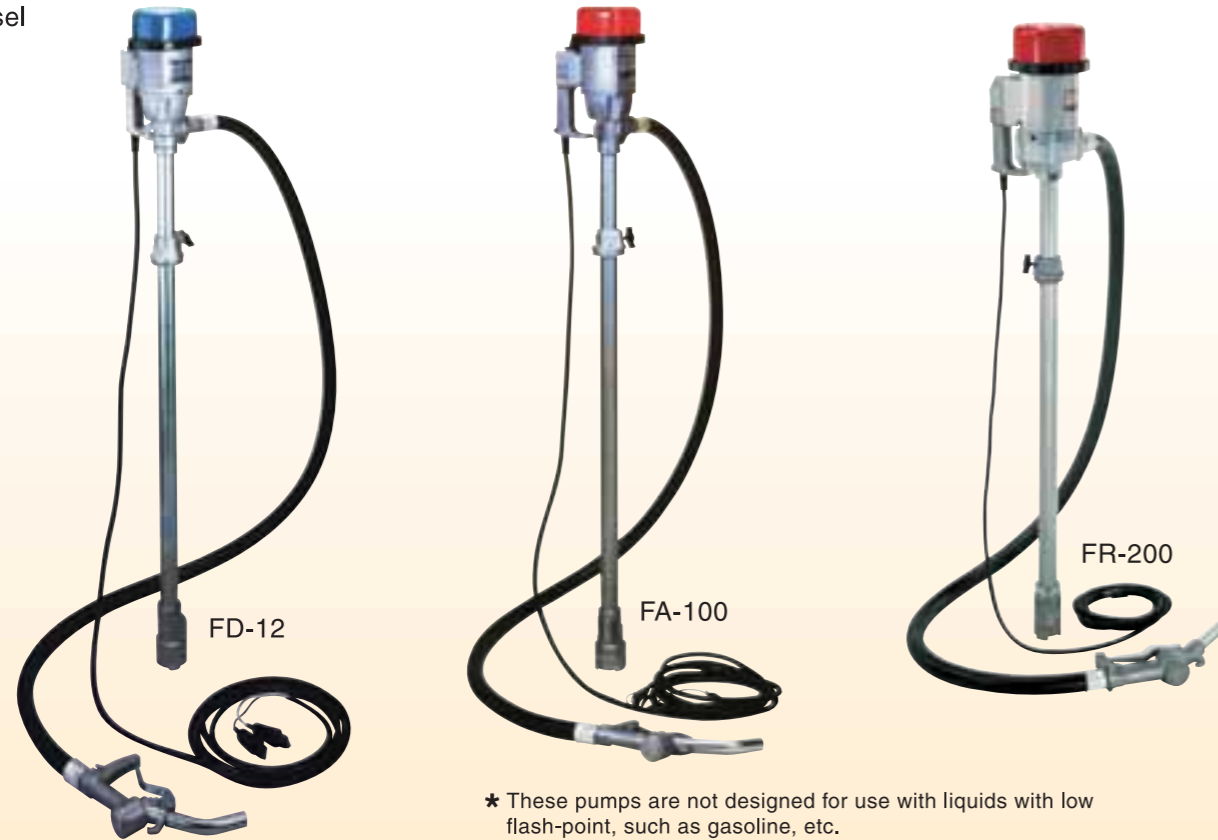

* These pumps are not designed for use with liquids with low flash-point, such as gasoline, etc.

■ Specifications

	Model	FD-12	FD-24	FA-100	FR-200
PUMP	Connection Dia	20 mm (3/4")			32 mm (1 1/4")
	Connection Thread	Inner Pipe Thread			
	Total Head	6 m (19 ft)	7 m (23 ft)		11 m (36 ft)
	Delivery Volume	40 L/min (10 USG/min) (Kerosene, Light Oil)	50 L/min (13 USG/min) (Kerosene, Light Oil)		110 L/min (29 USG/min) (Kerosene, Diesel)
MOTOR	Type	Enclosed Fan-Cooled Commutator			Fan-Cooled Commutator
	Voltage	DC 12 V	DC 24 V	AC 110 V	AC 220 V – 240 V
	Rated Current	14 A	7 A	2 A	14 A
	Output	80 W	90 W	100 W	
	Revolution	7000 rpm	7300 rpm	7000 rpm	
	Rating	Continuous			
	Power cord	5 m (16.4 ft)			
	Delivery Hose	1 Oil-Proof Rubber Hose (2 m)			
Gross Weight	20 kg			30 kg	
Dimensions LxWxH (mm)	1228 x 291 x 172			1290 x 490 x 205	
Packing Unit	2				

Handy Pumps Suitable for Transferring Chemicals & Solvents



* Not suitable for food products.

- Quickly transfers liquids, 80 L/min (FC-103, FC-104)
- With adjusting valve, delivery volume can be easily changed.
- Strainer is located at the bottom of suction pipe to prevent sediment and contaminants from entering the suction pipe.
- Unique pump design does not disturb liquids. By using this flow structure less "whirlpools". Useful with liquids that are easily disturbed or can be easily aerated, this design prevents air from being mixed with the pumped liquids.
- Durable motor
Totally enclosed motors airtight construction ensures long term reliability. Cool air intake prevents motor from overheating.
- Designed to pump volatile liquids.
Models, FC-103 and FC-104 are air motor operated and can be used with volatile liquids.

■ Performance Curve

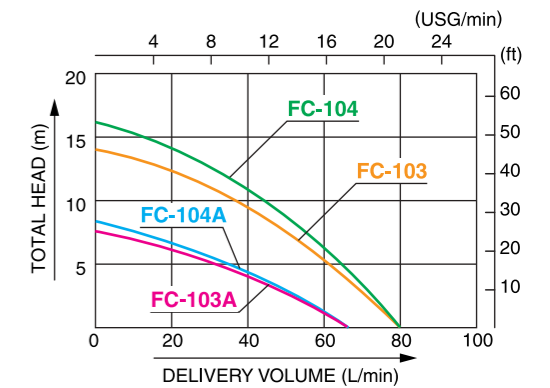

■ Applications

- Transferring liquids from larger drums, barrels and other large bulk containers to smaller, volume containers.



■ Specifications

	Model	FC-103	FC-104	FC-103A	FC-104A
PUMP	Total Head	16 m (52 ft)	14 m (46 ft)	7.5 m (25 ft)	8 m (26 ft)
	Delivery Volume	80 L/min (21 USG/min)		65 L/min (17 USG/min)	
	Max. Temperature	60 °C			
	Flow Control	Valve			
MOTOR	Type	Electric Motor		Air Motor	
	Voltage	AC 100 V Single Phase 4 A		Air Pressure	0.3 – 0.7 MPa
	Frequency	50 / 60 Hz		Air Consumption	500 NL/min
	Output	160 W		Air Hose Inside Dia	φ 8
	Power Code	4.7 m (15 ft)		Compressor	Continuous
	Standard	FC-103(A)	1 PVC Delivery Hose (25 A x 1.3 m), 1 PVC Ball Cock (20 A), 1 Hose Band (φ 32)		
	Accessories	FC-104(A)	1 SUS304 Delivery Hose (25 A x 1.5 m), 1 SUS405 Ball Cock (25 A)		
	Gross Weight	6.5 kg	5 kg	10.4 kg	8.7 kg
Dimensions LxWxH (mm)	1290 x 190 x 250				
Packing Unit	1				

■ Liquid Sur faced Material

Mode	FC-103 FC-103A	FC-104 FC-104A
Outer Pipe	Polypropylene	SUS 304
Inner Pipe	Polypropylene	SUS 304
Impeller	PVDF	
Shaft	Hastelloy C	
Valve	PVC	SUS 304
Other Parts	Polypropylene	
Metal	PTFE	
Hose	PVC	SUS 304

* These pumps are not designed for use with liquids with low flash-point, such as gasoline, etc.

- PVDF: Polyvinylidene fluoride
- PTFE: Polytetrafluoroethylene
- P V C : Polyvinyl chloride

FOR FISHERY INDUSTRY

One Switch for Rolling Up and Down Automatic Anchor Winch for Leisure Boat Use

- Automatic rolling system, chain/rope available.
- Made with stainless alloy to limit corrosion.
- Stylish design.



Rope Guide

RA-2012H

Recommendation

	Rope	Chain	Anchor
Size	12 mm Rope 3 Wire Rope	6 mm Short Link Chain (Stainless)	Max. Approx. 7 kg (Recommend: Danforce)
Length	Approx. 100 m	Approx. 5 m	_____
Remark	11 kg – 18 kg (Dry)	6 kg – 8kg	_____

Specifications

Model	RA-2012H
Voltage	DC 12V (±10%)
Rated Current	24 A (40 kg) – 65 A (120 kg)
Motor Output	200 W
Rating	1 hr / 24 A
Roller Revolution	80 rpm
Manual Capacity	Max. 120 kg (65 A)
Capacity Rating	40 kg [20 m/min (65 ft/min)]
Winch Speed (Max.)	24 m/min (79 ft/mn)
Down Rolling Speed (Max.)	30 m/min (98 ft/mn)
Standard Accessories	1 Power Cord (8mm ² 2 cores x 8 m), 1 UP-DOWN Label, 6 Solderless Terminals (5.5mm ²), 8 Solderless Terminals (8mm ²), 3 Connection Cords, 1 Rope Guide, 6 Tab-on Terminals, 3 Roll Washers, 1 Breaker (30A), 6 M4 +Screws & Nuts, 1 Toggle Switch
Gross Weight	19 kg
Dimensions LxWxH (mm)	460 x 255 x 324
Packing Unit	1

Performance Curve

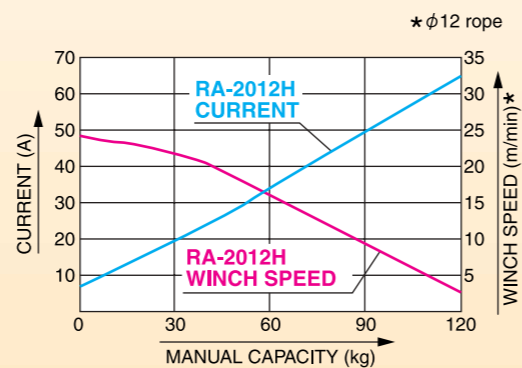

Operation Limit

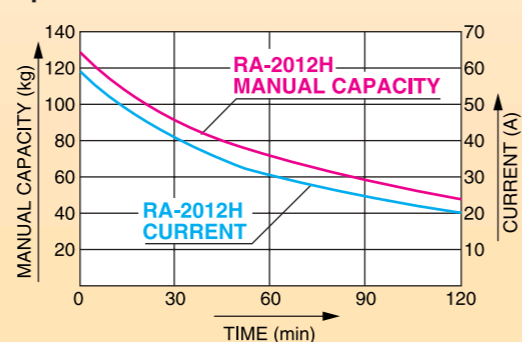

"MINI-CARL" Double Life Time with Titan Boron Alloy

- Compact and light.
- Alumite treatment for high durability anti-rusting.
- One button for all work.
- Changeable button location for more convenience.



RN-2012



RN-2012H

Performance Curve

• RN-2012

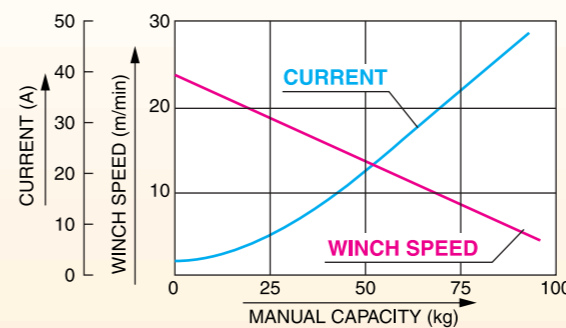

• RN-2024H

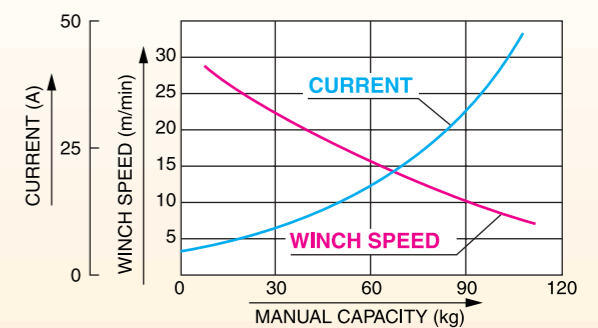

• RN-2012H

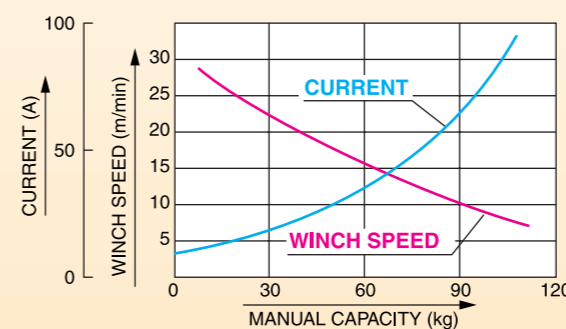

• RN-2512H

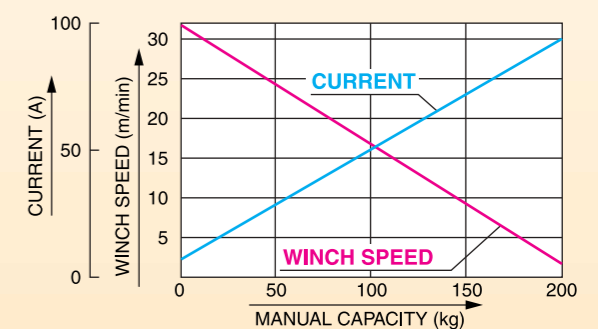

Specifications

Model	RN-2012	RN-2012H	RN-2024H	RN-2512H
Voltage	DC 12 V		DC 24 V	DC 12 V
Rated Current	15 A	24 A	13 A	30 A
Motor Output	140 W	200 W		250 W
Rating	1 h / 15 A	1 h / 24 A	1 h / 13 A	1 h / 30 A
Roller Revolution	100 rpm			120 rpm
Manual Capacity (Max.)	50 kg (45 A)	120 kg (85 A)	120 kg (40 A)	200 kg (110 A)
Winch Speed	27 m/min (89 ft/min)			32 m/min (105 ft/min)
Breaker	15 A	30 A	20 A	30 A
Standard Accessories	1 Breaker, 1 Packing,	1 Power cord (5.5 mm ² x 10 m x 2 cores), 2 +Screws (M4 x 8),	2 Nuts (M4) 4 Solderless Terminals	
Net Weight	9 kg	13 kg	15 kg	
Packing Unit	1			

Anchor Winch for Fishing and Leisure Boat

- Easy to winch anchor.
- Changeable button location for more convenience.
- High anti-discoloration with denatured epoxy paint.



RED-2012H



RES-2012H

Compact Built-in Type

- REP type allows work while standing.
- For anchoring, recommend to use anchor davit (optional) together.



RSB-2012H



REP-2512H

■ Performance Curve

• RED-2012H, RES-2012H

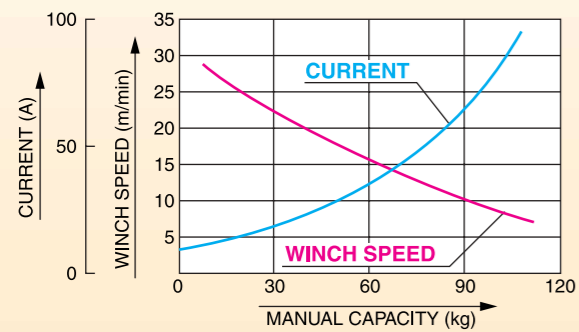

• RED-2012

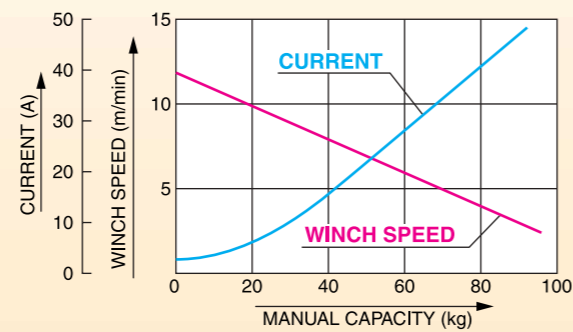

■ Performance Curve

• REP-2012H, RSB-2012H

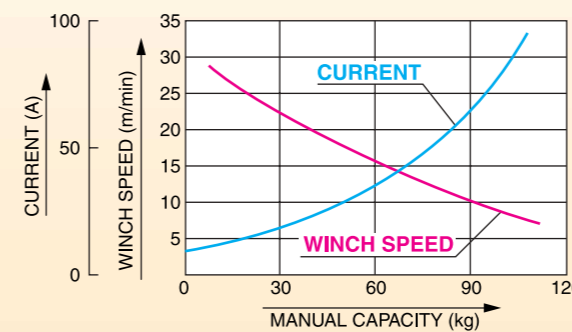

• REP-2512H, RSB-2512H

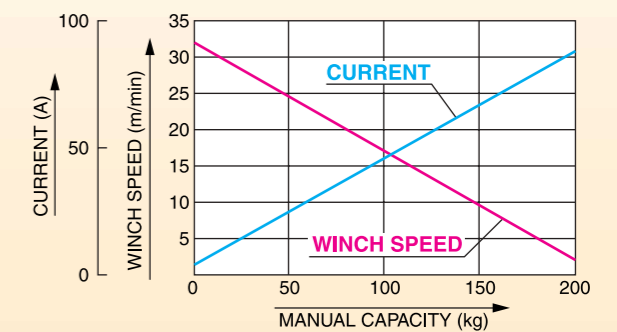

■ Specifications

Model	RED-2012H	RES-2012H	RED-2012
Voltage	DC 12 V		
Rated Current	24 A		15 A
Motor Output	200 W		140 W
Rating	1 h / 24 A		1 h / 15 A
Roller Revolution (Max.)	100 rpm		50 rpm
Manual Capacity (Max.)	120 kg (85 A)		100 kg (45 A)
Winch Speed	27 m/min (89 ft/min)		11.5 m/min (38 ft/min)
Breaker	30 A		15 A
Standard Accessories	1 Breaker, 1 Packing,	1 Power cord (5.5 mm ² × 10 m × 2 cores), 2 + Screws (M4 × 8),	2 Nuts (M4), 4 Solderless Terminals
Net Weight	13.5 kg		8.4 kg
Packing Unit	1		

■ Specifications

Model	REP-2012H	RSB-2012H	REP-2512H	RSB-2512H
Voltage	DC 12 V			
Rated Current	24 A		30 A	
Motor Output	200 W		250 W	
Rating	1 h / 24 A		1h / 30 A	
Roller Revolution (Max.)	100 rpm		120 rpm	
Manual Capacity (Max.)	120 kg (85 A)		200 kg (110 A)	
Winch Speed	27 m/min (89 ft/min)		32 m/min (105 ft/min)	
Breaker	30 A			
Standard Accessories	1 Breaker, 1 Packing,	1 Power cord (5.5 mm ² × 10 m × 2 cores), 2 + Screws (M4 × 8),	2 Nuts (M4), 4 Solderless Terminals	
Net Weight	14 kg	10.5 kg	15.5 kg	12 kg
Packing Unit	1			

Light weight & Compact Most Suitable for Fishing Boats

Applications

- Winding anchor for boats
- Drawing fishing net
- Towing line
- Winding up basket



RES-2512



REL-2512

Performance Curve

• RES-2512, REL-2512 (250 W, 12 V Type)

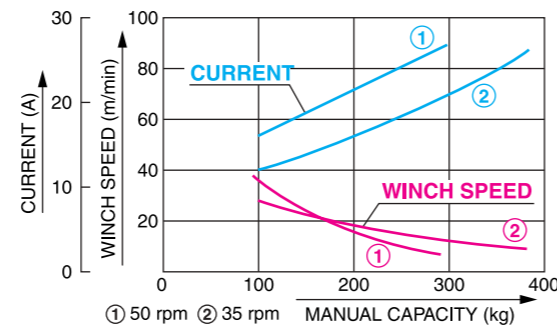

• REL-2524 (250 W, 24 V Type)

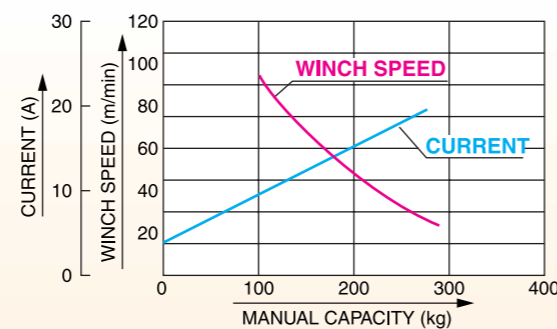

• RES-4024, REL/RES-4024 (400 W, 24 V Type)

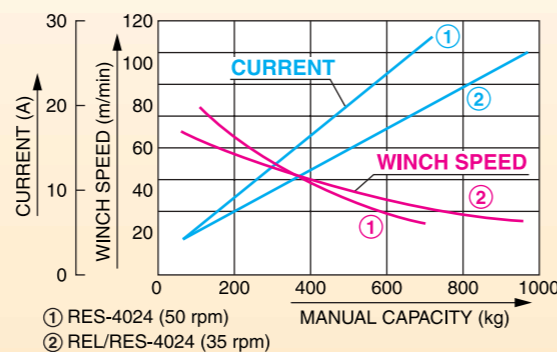

Specifications

Model	RES-2512	REL-2512	REL-2524	RES-4024	REL-4024	RES-4024L	REL-4024L
Voltage	DC 12 V		DC 24 V				
Rated Current	30 A		15 A	25 A			
Motor Output	250 W		400 W				
Rating	1 h / 30 A		1 h / 15 A	1 h / 25 A			
Roller Revolution	50 rpm (Low), 100 rpm (High)		100 rpm (Low/High)	50 rpm (Low), 100 rpm (High)		35 rpm (Low), 70 rpm (High)	
Manual Capacity	Max. 280 kg (Low), 140 kg (High), (90 A) Rating 90 kg (Low), 45 kg (High), (30 A)		300 kg (80 A) 140 kg (15 A)	700 kg (Low), 350 kg (High), (110 A) 140 kg (Low), 70 kg (High), (25 A)		900 kg (Low) 450 kg (High), (110 A) 200 kg (Low), 100 kg (High), (25 A)	
Winch Speed (With 100 kg Load)	6 m/min (19 ft/min) (Low) 13 m/min (42 ft/min) (High)		23 m/min (75 ft/min)	20 m/min (65 ft/min) (Low) 33 m/min (108 ft/min) (High)		15 m/min (49 ft/min) (Low) 25 m/min (82 ft/min) (High)	
Standard Accessories	1 Cable Gland for Ship, 1 Waterproofing Plate, 1 Vertical Type Main Body Packing, 5 Crimping Terminals, 1 Connection Terminal						
Gross Weight	20 kg	15 kg	14.5 kg	24 kg	21 kg	24 kg	21 kg
Dimensions LxWxH (mm)	478x245x285	570x250x285	478x245x285	478x245x285	570x250x285	478x245x285	570x250x285
Packing Unit	1						

Effective Electromagnetic Brake Model

- Motor case is made of corrosion resistance aluminum alloy to withstand seawater.
- Possible to stop instantly.

Applications

- Winding anchor for boats
- Drawing fishing net
- Towing line
- Winding up basket



REL-5524LB



RES-5524LB

Specifications

Model	RES-5524LB	REL-5524LB
Voltage	DC 24 V	
Rated Current	31 A	
Motor Output	550 W	
Rating	1 h / 31 A	
Roller Revolution	35 rpm (Low), 70 rpm (High)	
Manual Capacity	Max. 1000 kg (Low), 500 kg (High), (120 A) Rating 280 kg (Low), 140 kg (High), (31 A)	
Winch Speed (With 100 kg Load)	15 m/min (49 ft/min) (Low) 25 m/min (82 ft/min) (High)	
Electromagnetic Brake	Static Friction Torque	4 N·m
	Rated Voltage	DC 24 V
	Rated Capacity	15 W
Standard Accessories	1 Waterproofing Plate, 1 Vertical Type Main Body Packing, 5 Machine Screws M5x20	
Gross Weight	30 kg	
Dimensions LxWxH (mm)	593 x 330 x 355	
Packing Unit	1	

Performance Curve

• RES-5524LB, REL-5524LB (250 W, 12 V Type)

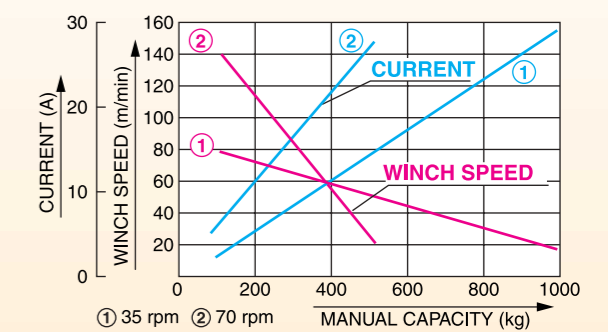

ECARL BOX Just Changing Box Makes Your ECARL New

Example:
REL+REF



RES-330A
Suitable model:
• All REL model



RES-330B
with 3-button switch
Suitable model:
• All REL model



REF-300
Suitable model:
• REL-2512
• REL-2524
• REL-4024
• REL-4024L



REF-330
Suitable model:
• All REL model



3-button switch
Suitable model:
• RES-330B
• Attached to REF-330

High Speed & High Load Rolling Up Max. Winch Up Power 900 kg

- Use magnet motor. Simple wiring and easy to switch direction between clockwise to counterclockwise.
- Approx. 25 % more power from usual 400 W type by high speed and high load rolling up.
- 2 stage switchable winch capacity (REL, RES).
Switch to 900 kg / 50 rpm and 450 kg / 100 rpm by gearshift.
- Motor case, Roller, etc are made of aluminum alloy.
Light, compact, sea water proof and no rust damage to FRP boat.
- Polyurethane coat protects corrosion perfectly.



Performance Curve

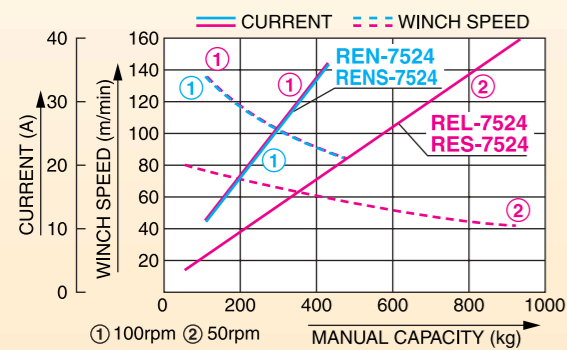

Specifications

Model	REN-7524	RENS-7524	REL-7524	RES-7524
Voltage	DC 24 V			
Rated Current	43 A			
Motor Output	750 W			
Rating	1 h / 43 A			
Roller Revolution	100 rpm	50 rpm (Low), 100 rpm (High)		
Manual Capacity	Max. 450 kg (150 A)	900 kg (Low), 450 kg (High), (150 A)		
Capacity Rating	110 kg (43 A)	220 kg (Low), 110 kg (High), (43 A)		
Winch Speed	33 m/min (108 ft/min)	17 m/min (55 ft/min) (Low), 33 m/min (108 ft/min) (High)		
Standard Accessories (RES, REN Type Only)	1 Cable Gland For Ship, 1 Waterproofing Plate, 1 Vertical Type Main Body Packing, 2 Crimping Terminals,			
Net Weight	20.5 kg	30.5 kg	19.5 kg	24.5 kg
Dimensions LxWxH (mm)	510 x 280 x 290	585 x 315 x 330	520 x 280 x 270	570 x 275 x 285
Packing Unit	1			



Body : MR-2512
Roller : MR-120

Rolling Up Smoothly Without Damage to Net

- Dual-speed roller revolution (No load) :
20–30 rpm and 40–60 rpm.
- With 2-stage-switch and free revolution (20–60 rpm).
- For use, just connect to battery and after use, easy to take off.
- Roller itself and stand have a handle.
Possible to set roller to any direction.
- Reverse switch makes possible to do wide variety of work.

Rollers (options)

- Roller and guide are set.
- Roller spindle is made of gunmetal, so easy to take off.
- Rubber is made of synthesis rubber to protect from wear and tear.

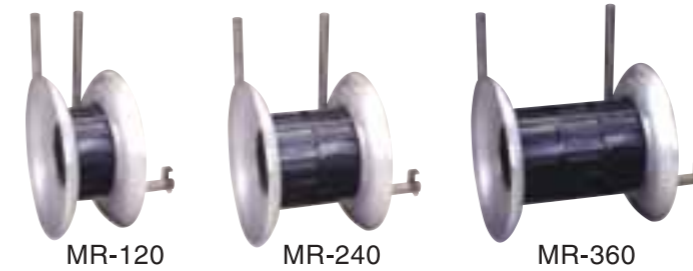

Performance Curve (20 rpm, Low)

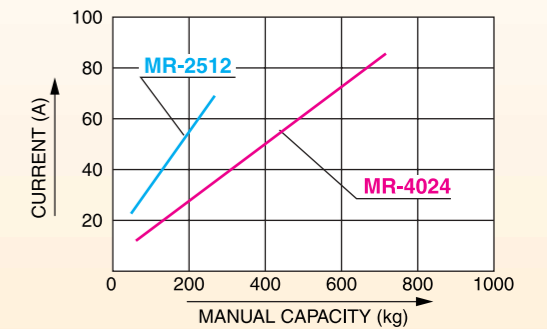
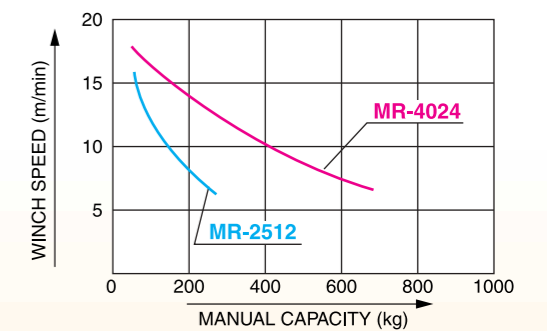

Operation Limit (20 rpm, Low)

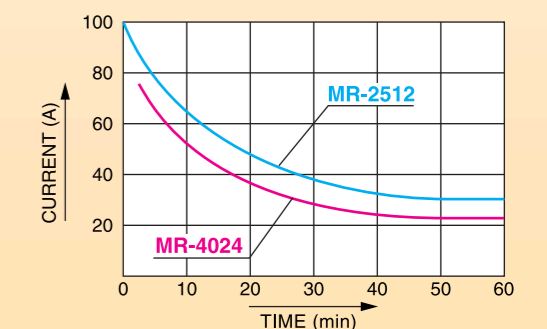
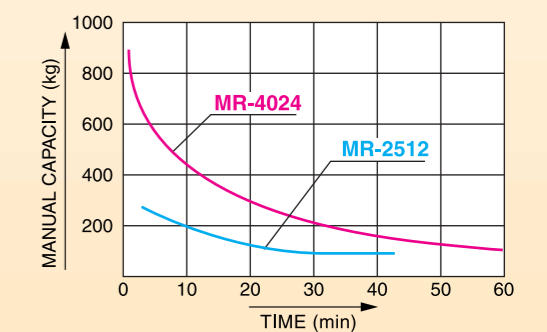

*Operate battery winch under the curve of operating limit.

Specifications

Model	MR-2512	MR-4024
Voltage	DC 12 V	DC 24 V
Rated Current	30 A	25 A
Motor Output	250 W	400 W
Rating	1 hr / 30 A	1 hr / 25 A
Roller Revolution (No Load)	20 rpm, Low 40 rpm, High	20 – 30 rpm 40 – 60 rpm
Manual Capacity	Max. (2 min)	250 kg / 900 kg
	Rating (1 hr)	125 kg / 450 kg
Winch Speed (100kg Load)	20 rpm, Low	80 kg / 200 kg
	40 rpm, High	40 kg / 100 kg
Winch Speed (100kg Load)	20 rpm, Low	12 m/min (39 ft/min) / 16 m/min (52 ft/min)
	40 rpm, High	22 m/min (72 ft/min) / 30 m/min (98 ft/min)
Net Weight	36 kg	38 kg
Dimensions LxWxH (mm)	685 x 588 x 308	
Packing Unit	1	

"PONDY" & "MARINE PET" Submersible Pump for Seawater

Applications

- Feeding or draining water in fish farms
- Washing purpose
- Draining bilge water



SK-2524



BL-2524N

Performance Curve

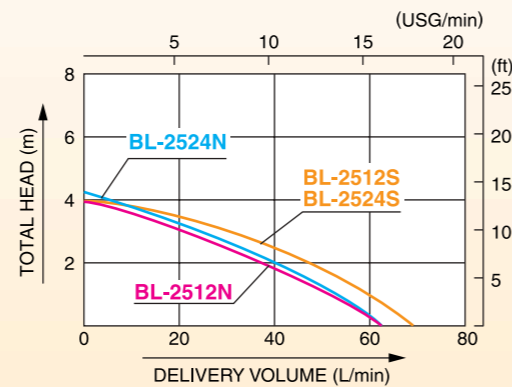
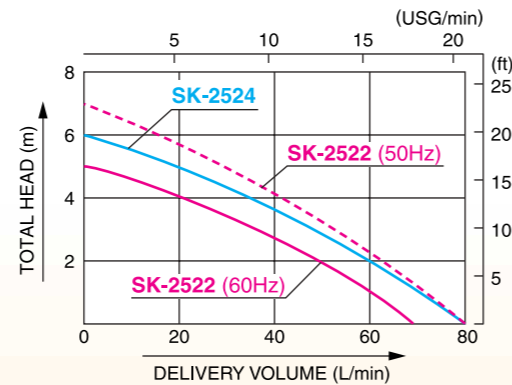

Specifications

	SK-2522		SK-2524	BL-2512S	BL-2524S	BL-2512N	BL-2524N
Connection Dia	25 mm (1")						
Total Head	5 m (16 ft)	7 m (23 ft)	6 m (19 ft)	4 m (13 ft)		4.2 m (13 ft)	
Delivery Volume	70 L/min (18 USG/min)	80 L/min (21 USG/min)		70 L/min (18 USG/min)		63 L/min (16 USG/min)	
Voltage	AC 220 V	AC 220 V	DC 24 V	DC 12 V	DC 24 V	DC 12 V	DC 24 V
Frequency	50 Hz	60 Hz	—	—	—	—	—
Rated Current	0.9 A	1.1 A	8.5 A	5.4 A	2.5 A	7.8 A	3.8 A
Rating	Continuous						
Output	100 W		123 W	45 W		50 W	
Revolution	2800 rpm		3200 rpm	5400 rpm		5800 rpm	
Standard Accessories	1 Coupling Set (φ 25) 1 Hose Nipple (φ 20) 1 Hose Band (φ 32) 1 Hose Band (φ 26) 1 Rope (5 m)		1 Coupling Set (φ 25) 1 Hose Nipple (φ 20) 1 Hose Band (φ 32) 1 Hose Band (φ 26) 1 Rope (5 m)		—		1 Elbow
Gross Weight	13 kg		20 kg		32 kg		
Dimensions LxWxH (mm)	240 x 420 x 310		568 x 286 x 373		574 x 283 x 403		
Packing Unit	2		20		20		

"NEW BILGE KING" Necessities for Boat

- Auto-stop feature prevents dry running, increases pump performance and life.
- Easy to use starter switch. Integrated fuse and switch assembly for ease of maintenance. Separate switch can be attached anywhere you want.
- Strainer and switch are made of a special sea water and oil resistance resin for longer durability.
- Two stage system of axial flow vane and spiral vane
- Easy to clean strainer.

Applications

- Draining of water and oil/water mix from bilge



BK-12



Standard Accessories

Type S Pump for without Accessories For Replacement "BILGE PUMP"



BK-12S

How to Attach Pump

Attach pump at 45 degree angle to set suction mouth and delivery mouth face upper side with 4 screws (φ5×10). (See the picture below)

In a dry place, attach pump to the side of boat about 50 to 70 cm away from the bottom of the boat.

Choose the location to set the pump by considering the length of battery and starting switch cable (3 m).

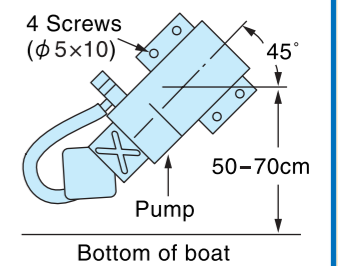

Specifications

Model	BK-12	BK-12S	BK-24	BK-24S
Suction / Delivery Dia	15 mm (1/2")			
Max. Delivery Volume	20 L/min (5 USG/min)			
Voltage	DC 12 V		DC 24 V	
Rated Current	10 A		5 A	
Suction Head	1 m (3 ft)			
Suction Time	2 - 5 sec (20 °C)			
Rating	80 W		90 W	
Standard Accessories (*Type S : Not Included)	1 Code with Starting Switch, 4 Tapping Screws (5×10), 4 Tapping Screws (4×16), 1 Fuse (15 A)	1 Strainer, 4 Tapping Screws (4×20), 1 Water Proofing Connector (Only S Type)	1 Delivery Nozzle, 4 Tapping Screws (4×10),	1 Delivery Nozzle Nat, 4 Tapping Screws (4×10), 1 Hose (3 m), 1 Fuse (8 A)
Net Weight	2.3 kg		2.3 kg	

*BK-12S, BK24S is pump for replacement.

"REVOLVEX PUMPS" Flexible Rubber Impeller for Seawater



- Complete structure is manufactured from gunmetal, no rusting.
- START/STOP is easily controlled by pressing one switch. (MFC type)
- MFC type is fitted with electromagnetic clutch.
- Easy to replace rubber impeller.
- Self-priming.

Performance Curve

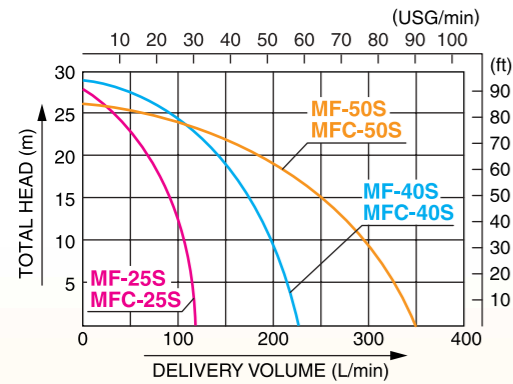

MF-25S

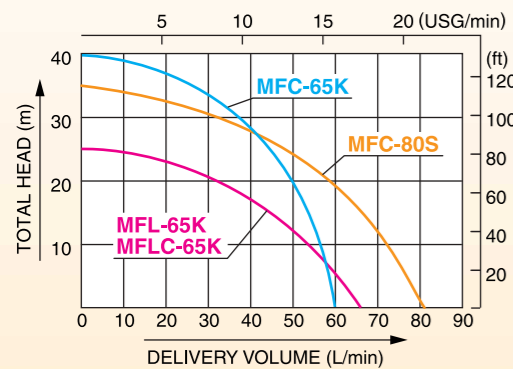

MFC-40S

For Seaweed Model Pumping Up Seaweed at Once, And Transferring it without Damage



- Adopted special impeller to avoid damage by seaweed.
- Special sleeve to transfer seaweed smoothly.

Applications

- Transfer seaweed from small boat to mother ship
- Built in for the machinery for seaweed
- Discharge of bilge water, emergency water discharge
- Washing a deck or hold



MFC-80S

Specifications

(*Products by order)

Model	MF-25S	MF-40S	MF-50S	MFC-65K*	MFC-80S*	MFLC-65K*	MFL-65K*
Connection Dia	25 mm (1")	40 mm (1½")	50 mm (2")	65 mm (2½")	80 mm (3")	65 mm (2½")	
Connection Thread	Inner Pipe Thread						
Material	Bronze Castings (Gunmetal)						
Total Head	28 m (92 ft)	29 m (95 ft)	26 m (85 ft)	40 m (131 ft)	35 m (114 ft)	24 m (78 ft)	
Delivery Volume	115 L/min (30 USG/min)	215 L/min (56 USG/min)	350 L/min (92 USG/min)	600 L/min (158 USG/min)	820 L/min (216 USG/min)	650 L/min (171 USG/min)	
Output	1.5 kw (2.0 PS) / 1750 rpm		3.7 kw (5.0 PS) / 1750 rpm		5.5 kW (7.5 PS) / 1,750 rpm		7.5 kW (10.2 PS) / 1,750 rpm
Number of Blades	9			11		13	
Driving Method	Belt Drive						
Revolution Direction	Anti-clockwise (Watching from Driving Shaft)						
Revolution	500 – 2300 rpm						
Shaft Dia	20 mm (¾")		25 mm (1")		Electromagnetic Clutch		25 mm (1")
Standard Accessory	Parallel Key						
Net Weight	4.8 kg	6 kg	11.6 kg	24.5 kg	31.5 kg	24.5 kg	19.5 kg
Dimensions LxWxH (mm)	250x152x198	270x168x206	347x196x241	460x240x285	430x240x280	480x234x285	460x234x285
Packing Unit	1						

Electromagnetic Clutch Specifications

*In case power is supplied by general purpose engine, choose MFC series (with clutch). (Need power source for clutch.)

Model	MFC-2524S	MFC-4024S	MFC-5024S	Model	MFC-65K MFC-80S MFLC-65K
Pump	MF-25S	MF-40S	MF-50S		
Voltage (Clutch)	DC 24 V				
Capacity (Clutch)	43 W				
Pulley	φ 136.5 (B-1)				
Net Weight (Clutch)	7.6 kg	8.8 kg	18.3 kg		
Dimensions LxWxH (mm)	272 x 160 x 205	292 x 178 x 198	408 x 203 x 223		
Packing Unit	1				
				Voltage	DC 24 V
				Capacity	36 W
				Pulley	φ 130

MF Series Impeller List

For "REVOLVEX PUMPS" & "RUBBER MASTER"

Spline Type Impeller

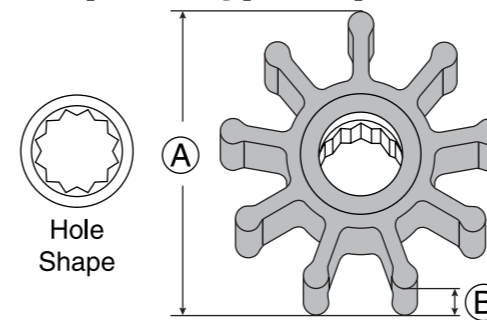

MF-25SRL (For MF-25S) (For Seawater)

Key Type Impeller

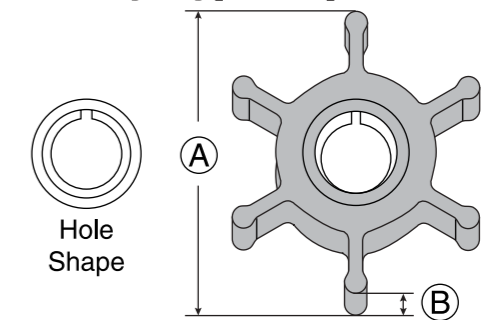

MFL-65KR (For MFL-65K, MFLC-65K) (For Seawater)

Model	MF-25S MFC-25S	MF-40S MFC-40S	MF-50S MFC-50S MFC-50SX	MFC-65K	MFL-65K MFLC-65K	MFC-80S	MF-40MS	MF-2524	MF-4024X
Application	Seawater							Oil	Seawater
Impeller Model	MF-25SRL	MF-40SRL	MF-50SRL	MF-65KR	MFL-65KR	MF-80SR	MF-40SRL	MF-2524KR	MF-4024KR
(A) Outside Dia	80 mm	94 mm		128.5 mm	143 mm	94 mm		65 mm	90 mm
(B) Thickness	54 mm	63 mm	95 mm	102 mm	105.4 mm	63 mm		41 mm	46 mm
Number of Blades	9			11	6	13	9	8	
Shape of Shaft	Spline			Key		Spline		Key	
Material	Chloroprene Rubber (Neoprene)							Nitrile Butyl Rubber	Chloroprene Rubber (Neoprene)

Long Durability "REVOLVEX PUMP with MOTOR" & "RUBBER MASTER"

- Compact design and can be removed on the deck easily.
- Small and compact, but, large delivery volume for this class of pumps.
- They can be used continuously with motor fan.
- Dry prime pump, no need to prime with water, immediate suction.

Easy to Remove in The Ship



MF-40MS

Easy to Replace Carbon Brushes

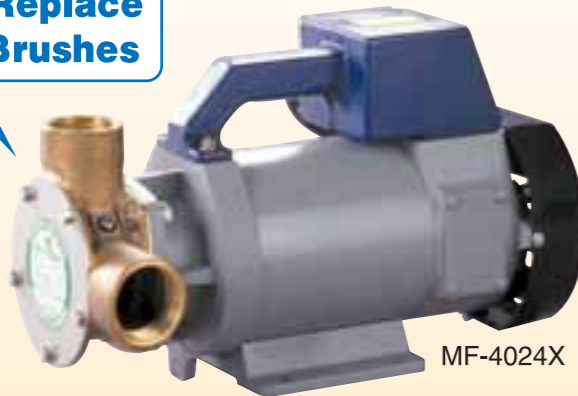

MF-4024X



* To transfer fuel, please use special impeller for oil. (Impeller type : MF-2524KN) Please refer to page 47.

Performance Curve

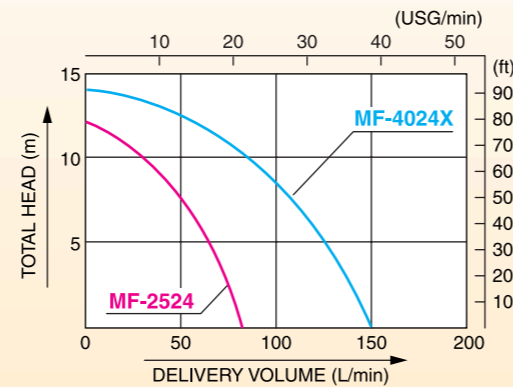
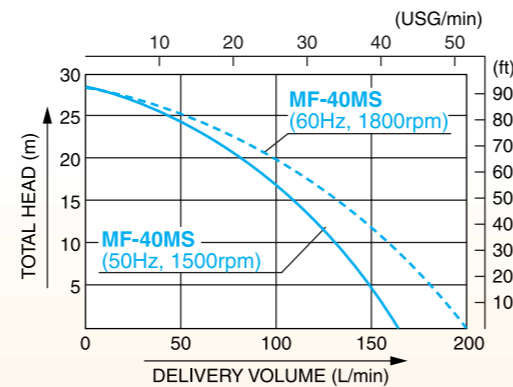

Specifications

Model	MF-40MS	MF-2524	MF-4024X
Connection Dia	40 mm (1½")	25 mm (1")	40 mm (1½")
Connection Thread	Inner Pipe Thread		
Material	Bronze Castings (Gunmetal)		
Total Head	29 m (95 ft)	35 m (114 ft)	14 m (46 ft)
Max. Self-Priming Head	5 m (16 ft)	3.5 m (11 ft)	
Delivery Volume	60 Hz : 200 L/min (52 USG/min) 50 Hz : 170 L/min (44 USG/min)	80 L/min (21 USG/min)	150 L/min (39 USG/min)
Voltage	Three Phase 200 V		DC 24V
Current	6.8 A / 50 Hz, 6.0 A / 60 Hz	12 - 15 A	22 - 30A
Output	1.5 kW	250 W	400 W
Power Cord	10 m (1.25 mm ²)	10 m (2.5 mm ²)	
Standard Accessories	1 Strainer, 1 Hose Band (φ48)	1 Strainer, 2 Connecting Nipples (φ32), 3 Hose Bands (φ32)	1 Strainer, 1 Hose Band (φ48)
Net Weight	24 kg	8.3 kg	20 kg
Dimensions LxWxH (mm)	498 x 254 x 359	315 x 213 x 238	429 x 230 x 295
Packing Unit		1	

"FS PUMPS" Marine Self-priming Pump for Seawater

- Specially designed for use with seawater.
- Pump and motor are constructed to withstand seawater and operated by a DC 24 V power source.
 1. Seawater proof motor: These motors are specially designed for seawater applications.
 2. Special aluminum compound for motor casing is made to withstand seawater corrosion. Moreover, this material does not add heavy weight to the pump.



FS-3224S

Specifications

Model	FS-2024S	FS-3224S
Connection Dia	20 mm (¾")	32 mm (1¼")
Connection Thread	Inner Pipe Thread	
Total Head	9 m (30 ft)	18.5 m (60 ft)
Delivery Volume	50 L/min (13 USG/min)	100 L/min (26 USG/min)
Voltage	DC 24 V	
Rated Current	7 A	16 A
Output	90 W / 7000 rpm	200 W / 6200 rpm
Rating	Continuous	
Power Cord	3 m (10 ft)	5 m (16 ft)
Standard Accessories	1 Strainer, 2 Hose Nipples, 1 Set Carbon Brush	
Gross Weight	28.5 kg	28 kg
Dimensions LxWxH (mm)	790 x 305 x 252	565 x 395 x 340
Packing Unit	5	3

Performance Curve

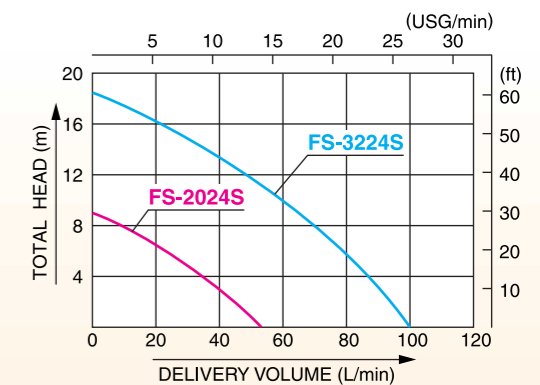

Application for Koshin Marine Products

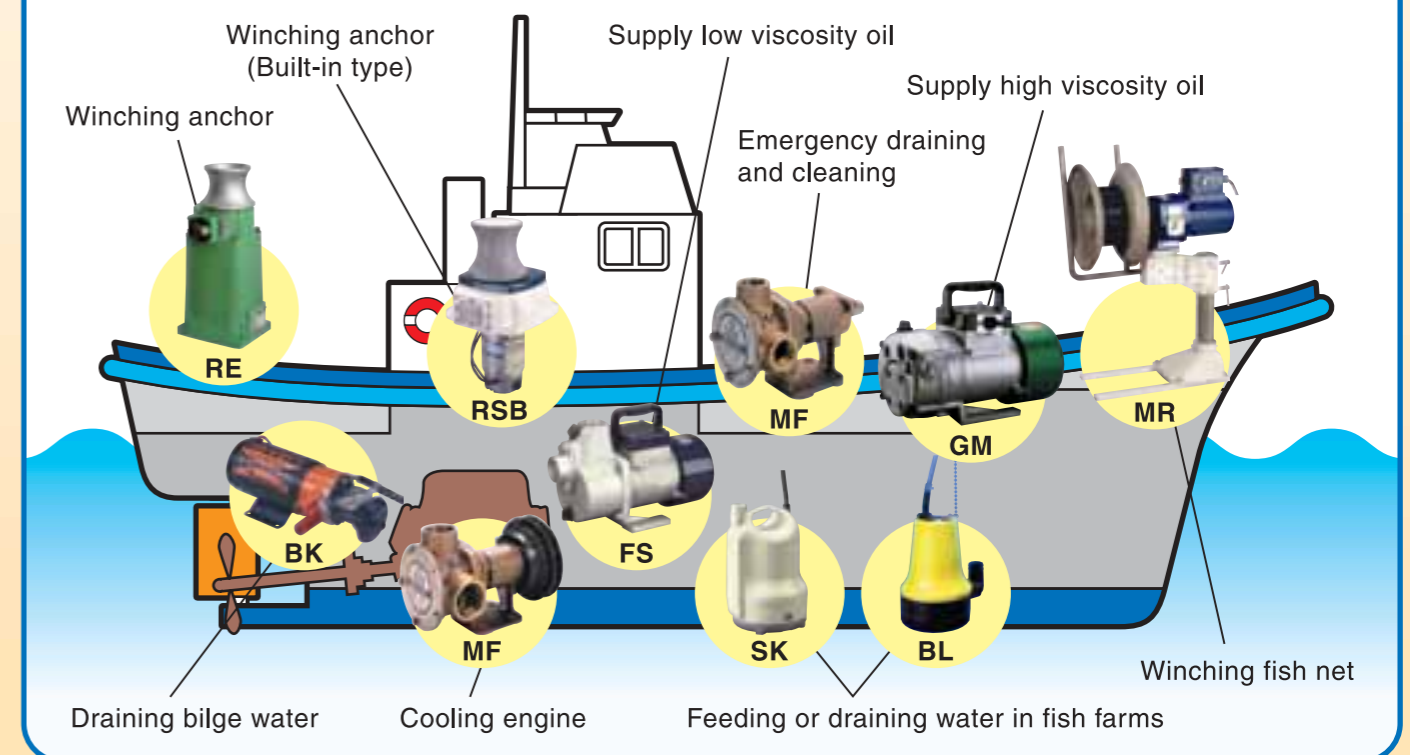

PABOOL PUMP SU-

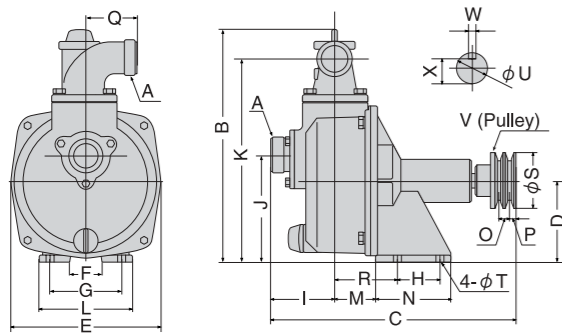

Model	A	B	C	D	E	G	H	I	J	K	L
SU-25	PS1"	273	260	90	174	130	45	92	121	242	150
SUR-25V	PS1"	319	330	110	209	150	60	86	147	280	190
SU-40(V)	PS1½"	319	341	110	209	150	60	91	147	280	190
SU-50H	PS2"	327	371	115	238	175	80	100	152	287	205
SU-50V	PS2"	378	371	115	238	150	80	100	152	337	205
SU-80L	PS3"	428	404	130	270	205	85	122	175	371	235

M	N	O	P	Q	R	S	T	U	W	V (Pulley)
41	90	15	90	56	71	64	9	19	5	2½"xA2
52	108	15	108	60	85	64	11	19	5	2½"xA2
52	108	15	108	75	85	78	11	19	5	3"xA2
56	127	19	127	76	88	78	11	24	7	3"xB2
56	127	19	127	80	88	78	11	24	7	3"xB2
72	130	19	130	112	102	78	14	24	7	3"xB2

GEAR PUMP GL-

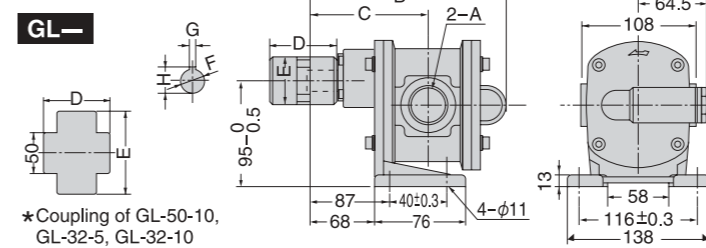

*Coupling of GL-50-10, GL-32-5, GL-32-10

Model	A	B	C	D	E	F	G	H
GL-13-5	PS½"	188.5	112.5	61		14 ^{+0.028} _{+0.008}	5 ^{+0.050} _{+0.020}	16.3 ^{+0.1} ₀
GL-13-5					55	19 ^{+0.030} _{+0.009}	6 ^{+0.035} _{+0.013}	21.8 ^{+0.1} ₀
GL-20-5	PS¾"	196.5	116.5	69		24 ^{+0.030} _{+0.009}		27.3 ^{+0.1} ₀
GL-25-5	PS1"	207.5	122				8 ^{+0.035} _{+0.013}	
GL-32-5	PS1¼"	222.5	129.5	93	125	28 ^{+0.030} _{+0.009}		31.3 ^{+0.1} ₀

GB- GC-

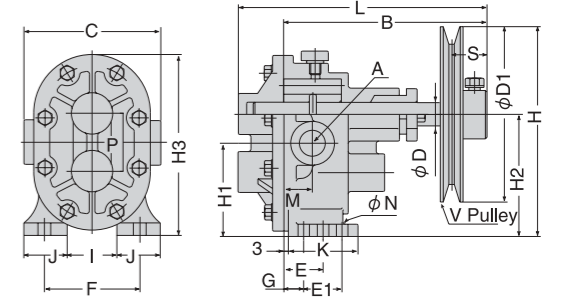

Type	A	L	B	C	D	D1	H	H1	H2	H3
GC-13/GB-13	PS½"	181	148	100	18	127	151	67	88	130
GC-20/GB-20	PS¾"	201	165	130	20	152	179	78	103	153
GC-25/GB-25	PS1"	247	204	142	22	203	230	91	129	191

F	J	I	K	E	G	E1	N	M	P	S	Pulley
70	32	36	51	33	-	-	9	21	41	25	A1
97	36	58	30	-	23	28	9	25	50	25	A1
114	38	65	75	-	30	34	10	33	63	24	A1

PONSTAR PS-

PB-

PSA-

PSK-53222

PKS-55022

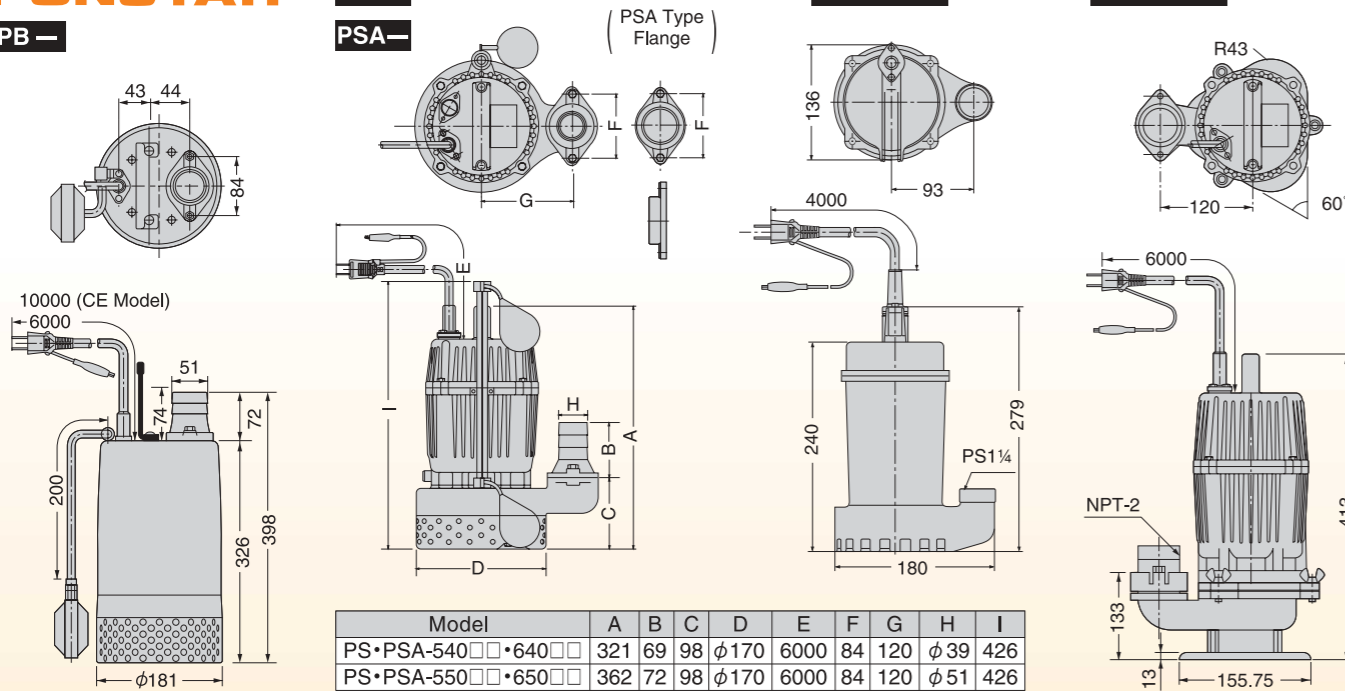

Model	A	B	C	D	E	F	G	H	I
PS-PSA-540□□□640□□	321	69	98	φ170	6000	84	120	φ39	426
PS-PSA-550□□□650□□	362	72	98	φ170	6000	84	120	φ51	426

FS PUMP FS-24D

FS-24D

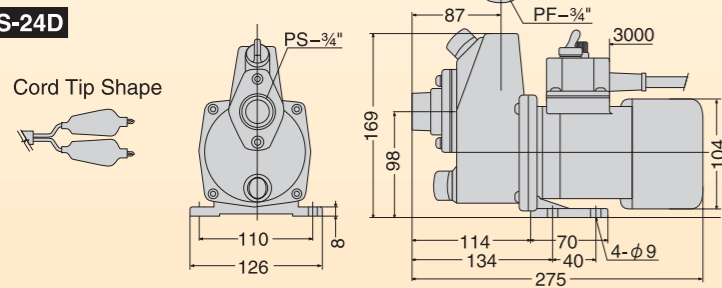

PX-

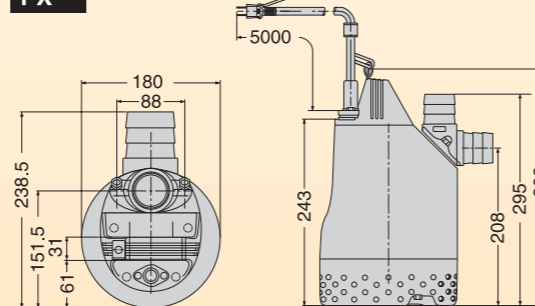

CHANGE-MASTER GM-2524H

GM-2524H

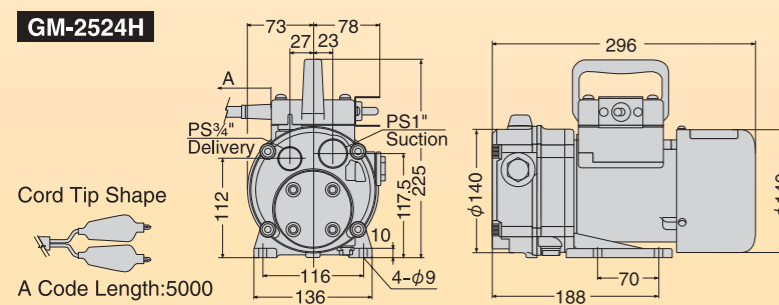

PXL-

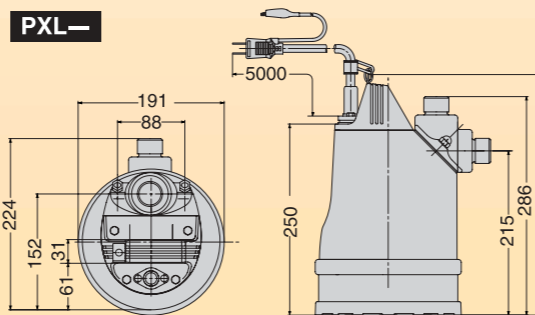

FILL PUMP FR-200

FR-200

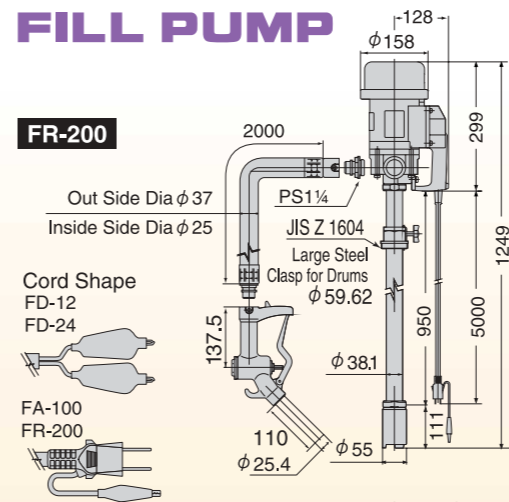

FD-12

FD-24

FA-100

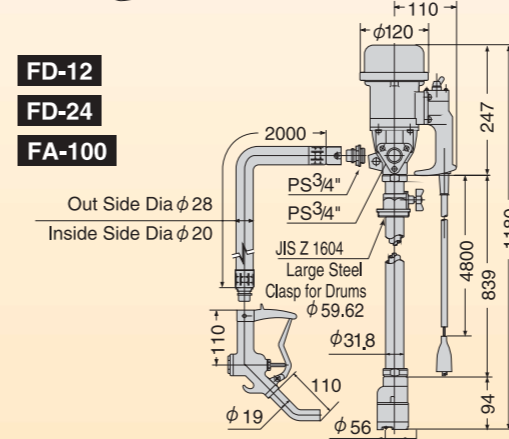

FC-103

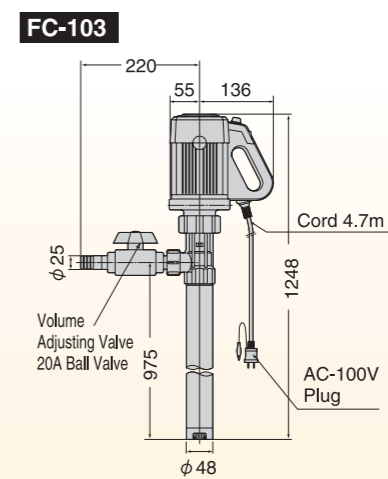

FC-103A

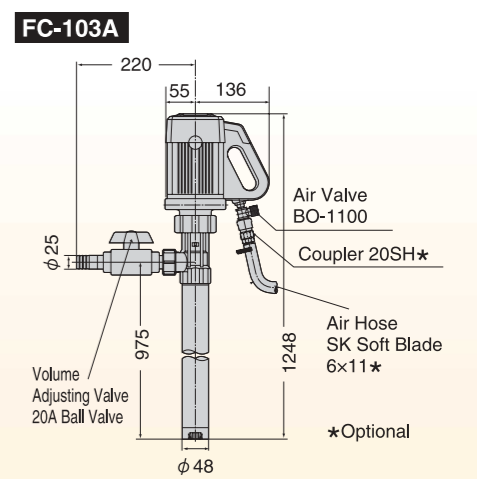

FC-104

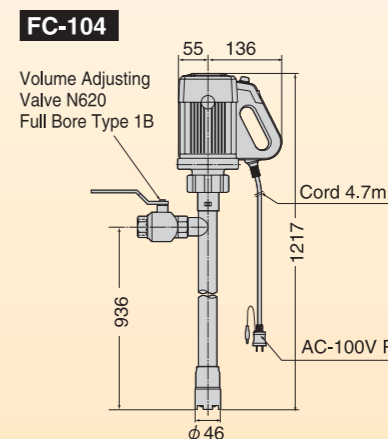

FC-104A

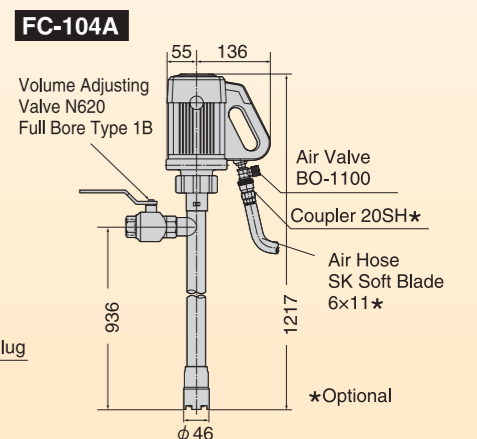

PONDY SK-2522

SK-2522

SK-2524

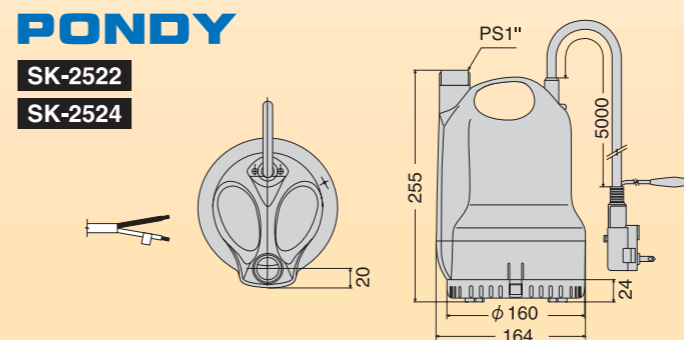

MARINE PET SK-2522

SK-2522

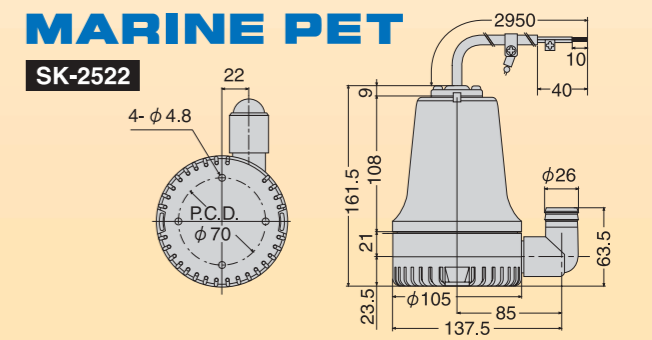

MINI-CARL

RN-2012H
RN-2512H
RN-2024H

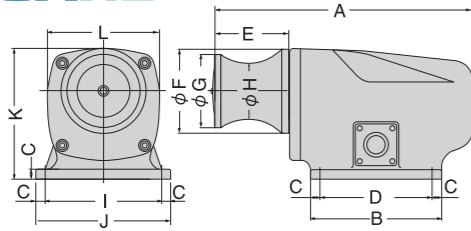

RED-2012H
RED-2024H
RED-2012

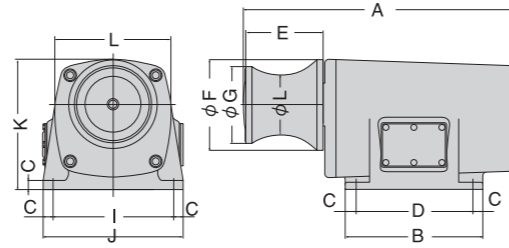

[Shaft Size]

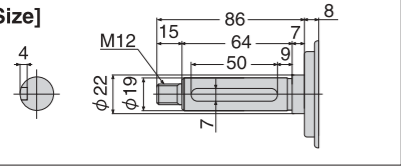

Model	A	B	C	D	E	F	G	H	I	J	K	L
RN-2012H-RN-2024H	403										203	
RN-2512H	433	205	15	175	116	132	114	87	180	210		174
RED-2012H-RED-2024H	402.5											192
RED-2012H	335.5											

RES-2012H

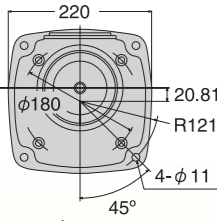

REP-2012H
REP-2512H

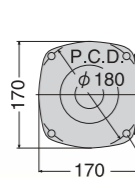

RSB-2012H
RSB-2512H

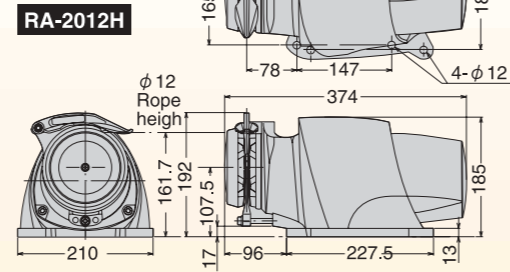
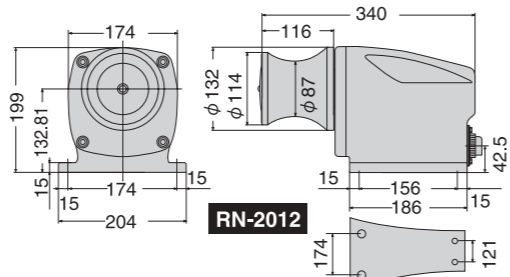
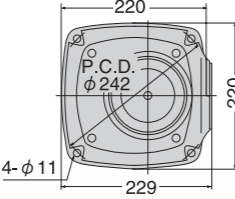

ECARL

[Shaft Size]

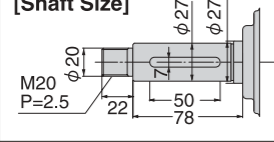

REL-5524LB

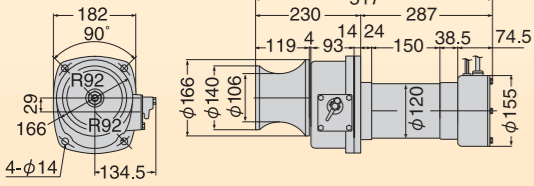

RES-5524LB

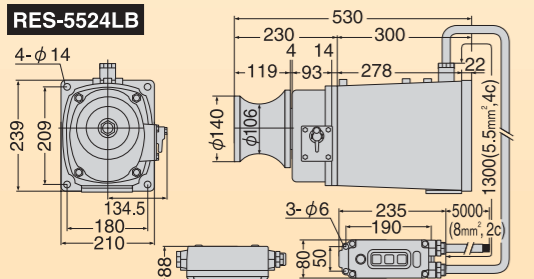

RES-2512
RES-4024(L)
RES-7524

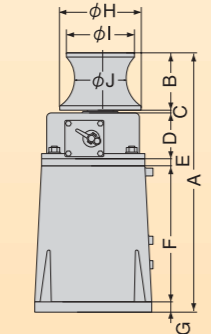
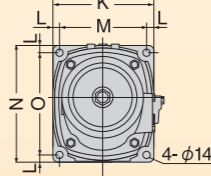

RENS-7524

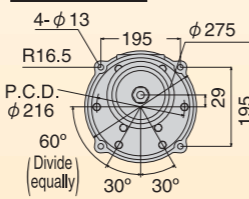

REL-2512
REL-2524
REL-4024(L)
REL-7524

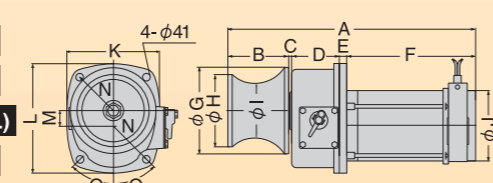
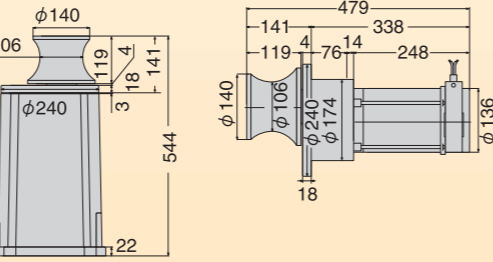

Model	A	B	C	D	E	F	G	H	I	J	K	L	M	N	O
RES-2512	530														
RES-4024(L)	119	4	93	14	278	22	166	140	106	210	15	180	239	209	
RES-7524	532	6													

Model	A	B	C	D	E	F	G	H	I	J	K	L	M	N	O
REL-2512(L)	427					197				113	182				
REL-2524	427	119	4	93	14	203	166	140	106	113	182	211	29	R92	45°
REL-4024(L)	433					203				136	182				
REL-7524	480	6				248									

ECARL BOX

RES-330A
RES-330B

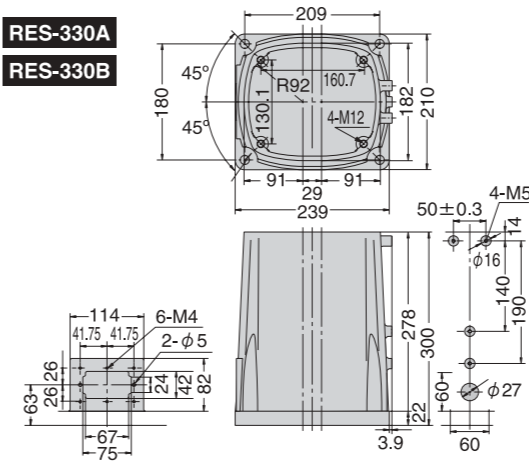

REF-300

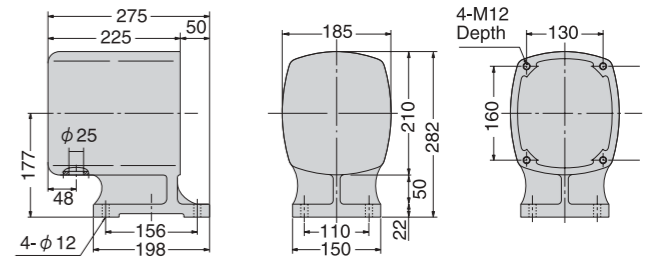

REF-330

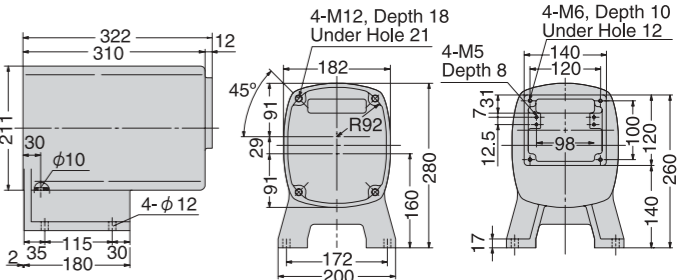

NEW BILGE KING

[Derivately Nozzle]

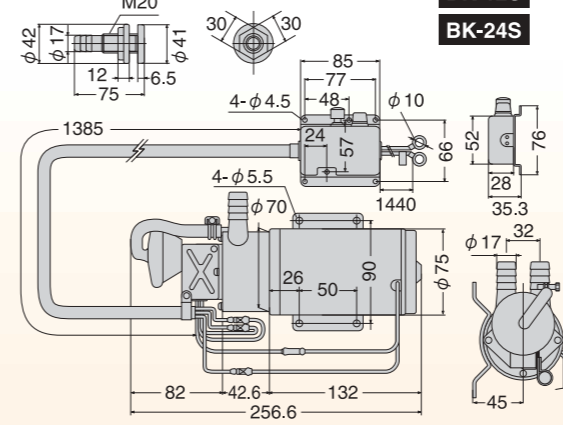

BK-12S
BK-24S

MAG-ROLLER

MR-

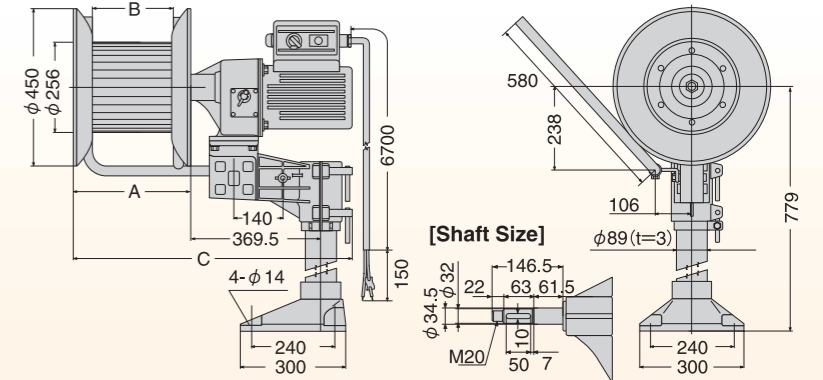

Model	A	B	C
MR-120	210	110	689.5
MR-240	328	228	807.5
MR-360	446	346	925.5

REVOLVEX PUMP

MF-40MS

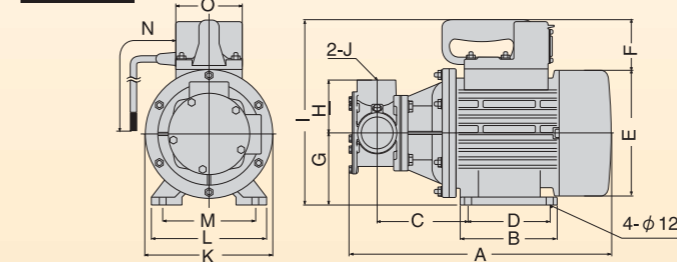

Model	A	B	C	D	E	F	G	H	I	J	K	L	M	N	O
MF-40MS	407	150	143	120	200	90	105	80	293	PS 1/2"	200	170	140	9700	120

RUBBER MASTER

MF-2524
MF-4024M

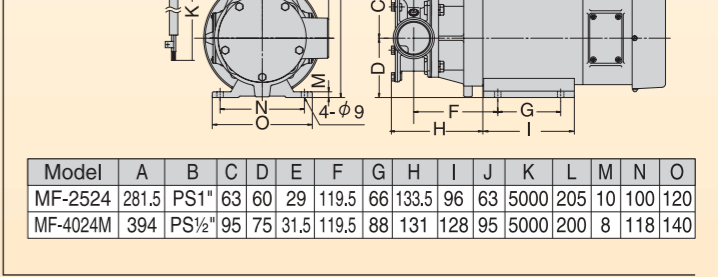

Model	A	B	C	D	E	F	G	H	I	J	K	L	M	N	O
MF-2524	281.5	PS 1"	63	60	29	119.5	66	133.5	96	63	5000	205	10	100	120
MF-4024M	394	PS 1/2"	95	75	31.5	119.5	88	131	128	95	5000	200	8	118	140

[Shaft Size]

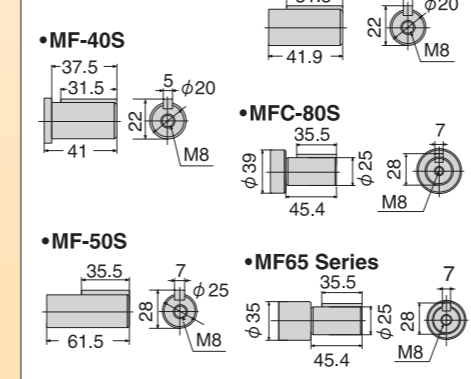

MF- **MFC-**

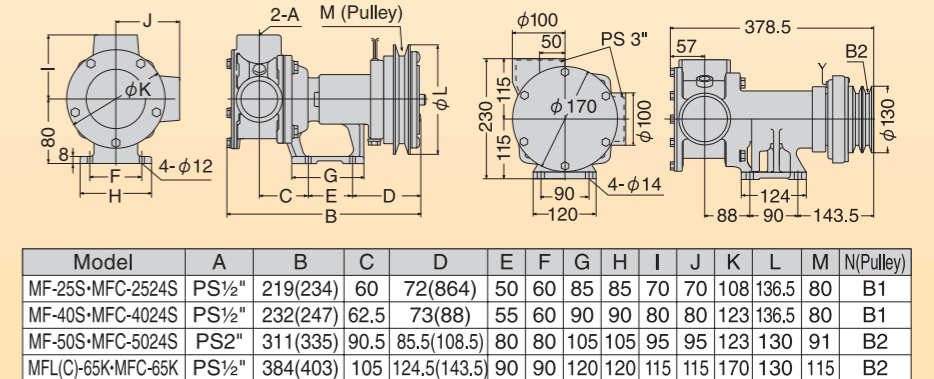

Model	A	B	C	D	E	F	G	H	I	J	K	L	M	N (Pulley)
MF-25S-MFC-2524S	PS 1/2"	219(234)	60	72(864)	50	60	85	85	70	70	108	136.5	80	B1
MF-40S-MFC-4024S	PS 1/2"	232(247)	62.5	73(88)	55	60	90	90	80	80	123	136.5	80	B1
MF-50S-MFC-5024S	PS 2"	311(335)	90.5	85.5(108.5)	80	80	105	105	95	95	123	130	91	B2
MFL(C)-65K-MFC-65K	PS 1/2"	384(403)	105	124.5(143.5)	90	90	120	120	115	115	170	130	115	B2